



aerospace
climate control
electromechanical
filtration
fluid & gas handling
hydraulics
pneumatics
process control
sealing & shielding



Hydraulic Hose, Fittings and Equipment

Technical Handbook



ENGINEERING YOUR SUCCESS.

Technology

Today's hose and fitting technology must meet the constantly increasing challenges and requirements of modern machines and equipment in demanding applications and arduous environments.

To satisfy these needs, Parker is continuously developing new state-of-the-art products and technologies.

Parkrimp *No-Skive* Technology – the safe connection

Hose fittings have an impact on the overall efficiency and safety of a hydraulic system.

The *No-Skive* concept was launched by Parker Hannifin some 30 years ago but continual development and the use of modern materials and production techniques have resulted in a state-of-the-art hose to fitting connector.

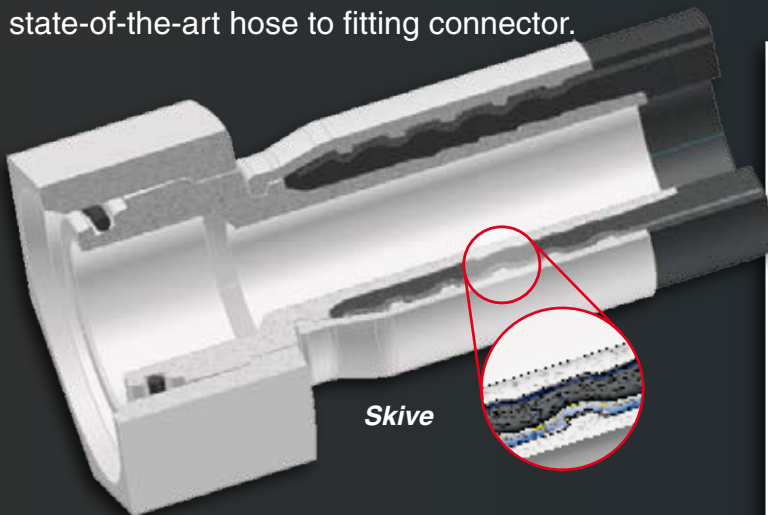

Skive

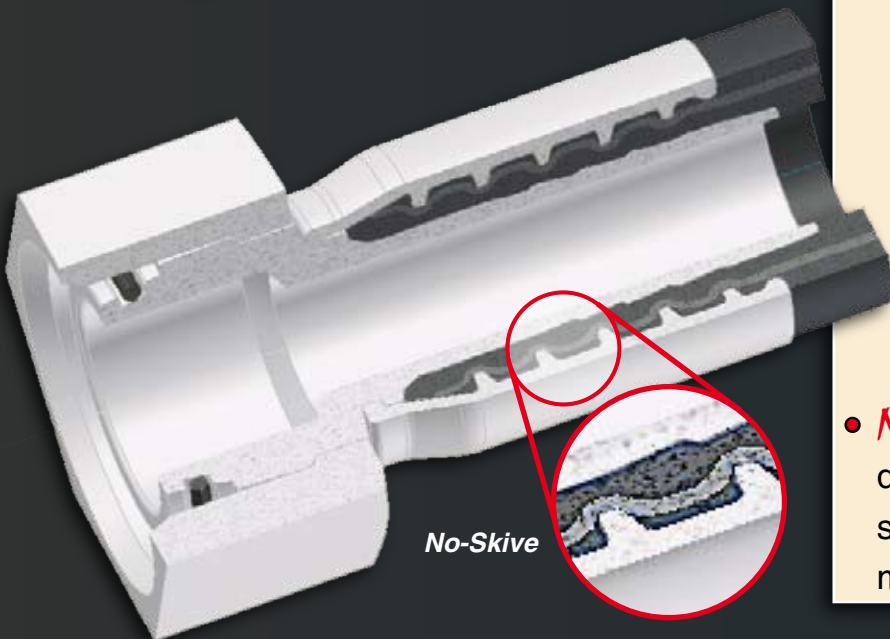

No-Skive

***No-Skive* versus Traditional Skive Fittings**

- Assembly of *No-Skive* hose and Cr(VI)-free fittings does not require removal of the outer cover of the hose:
 - Premature hose failure caused by under or over skiving is avoided.
 - The steel wire reinforcement is protected against corrosion.
 - The steel wire reinforcement is mechanically protected during hose fitting assembly by the outer rubber cover.
- *No-Skive* Cr(VI)-free fittings are designed so that the teeth of the shell bite down to the wire to give a metal-to-metal grip.

Parker Hose Products Division defines the power-grip connection between the crimp fitting and the hydraulic hose as the critical zone in all flexible hose connections. Correct combination of Parker *No-Skive* hose and fittings guarantees a total form lock connection between shell and reinforcement and assures a safe and leak free long service life.

Environmentally Friendly Plating Process



Since 1st July 2007 the EU End-of-life Vehicle Directive (ELV) came into force. European Community Directive 2000/53/EG of 1st July 2002

- Directive manages vehicle recycling
- Prohibition on the use of chromium-6, mercury and lead with specified exceptions and the prohibition of cadmium
- Metallic chromium and chromium-3 compounds may still be used

Chromium-6 has been classified in the EU Directive 67/548/EWG as Category 2, which means that this material can under certain circumstances act as a carcinogenic. Skin contact can bring about allergic reactions. Since 2006, all Parker steel fittings have been manufactured using trivalent chromate (Chromium-6-Free) plating. This new process enhances the corrosion resistance of the fittings, and is more environmentally friendly than the previous hexavalent chromate plating. While the fitting function will not change, the fitting color will. Fittings plated with trivalent chromate will be silver in color, not gold. The new plating process is implemented worldwide at all Parker facilities.

Custom Fittings for Short-Run or Special Applications

Non-standard and customised hose fittings are available from the Rapid Service Unit

The Rapid Service Unit (RSU) can provide:

- Jump sizes
- Specific end-configurations
- Specific drop lengths
- Fitting/tube combinations
- Customised prototypes
- Any batch size upwards from a single piece

Material options include steel, stainless steel, brass and special materials on request.



Going Green: The implications for hoses

Protecting the environment and controlling pollution are gaining momentum in response to priorities being set by governments and local authorities; it is becoming an important factor in the production of many products. Whether in municipal vehicles, construction equipment, agricultural machinery or forestry vehicles, the trend towards using biodegradable oil in hydraulic systems is increasing.

Hose Products Division Europe offers a full range of hoses with pure nitrile inner tubes, from 1 and 2 wire braided through to 6-layer multi-spiral hoses. These hoses offer exceptional hydraulic oil and biodegradable oil compatibility up to 100 °C together with the advantage of no loss in pressure capability.



Hybrid Push-Lok Technology – the excellent combination of two basic materials

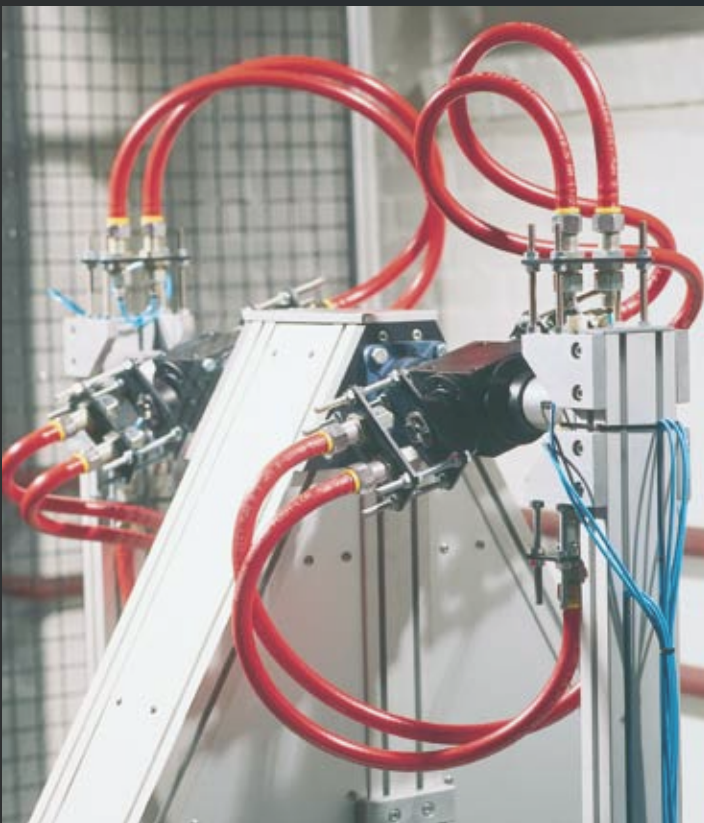

Through interactive development of both materials and manufacturing processes, the combination of polyurethane and synthetic elastomer has successfully resulted in the creation of a hybrid Push-Lok hose, with exceptional technical properties.

- Hose cover made of high-quality polyurethane, featuring high resistance to welding spatter and abrasion.
- The high tensile textile braid reinforcement ensures a firm grip of the hose onto the fitting and prevents it from pulling off.
- Synthetic elastomer core tube resistant to hydraulic fluids, dry air, water, water emulsions, etc.

Index

Hose and Fittings Terminology – The basics	Aa-1–Aa-4
Safety Pre-Caution	Aa-5
Safe Hose Assemblies in 8 Steps	Aa-6
1 Application	Aa-6
2 Size	Aa-6
3 Pressure	Aa-7
4 Temperature	Aa-7
5 Fluid Compatibility	Aa-8
6 Hose Fittings	Aa-8
7 Hose Assembly Manufacture	Aa-9–Aa-10
8 Routing / Installation / Environmental influences	Aa-11–Aa-13
How to Order (Part number description)	Aa-14–Aa-15

Technical Data

Hose Overview	Ab-2
Hose Fittings Pressure Ratings	Ab-3
Hose Fittings Overview	Ab-4–Ab-5
Hose Fitting Nomenclature	Ab-6–Ab-9
Classification Body Type Approvals	Ab-10–Ab-11
Conversion Chart	Ab-12
Temperature / Pressure Chart	Ab-13
Flow Capacity Nomogram	Ab-14
The Correct Method to Fit Female Swivel Ends	Ab-15
Chemical Resistance Table	Ab-16–Ab-21
Safety Guide	Ab-22–Ab-25
Identifying Fitting Types	Ab-26–Ab-35

Hose and Fittings Terminology – The basics !

Selecting the right hose and fittings combination usually belongs to the last steps in the design of a hydraulic system and its importance is often overlooked and underestimated. The right hose and fitting combination is however, vital for the overall functionality and long term service life of the complete system.

This technical handbook and catalogue will provide a guide to correct hose and fitting selection, as well as highlighting the important safety aspects to their usage as hose assemblies in the field.

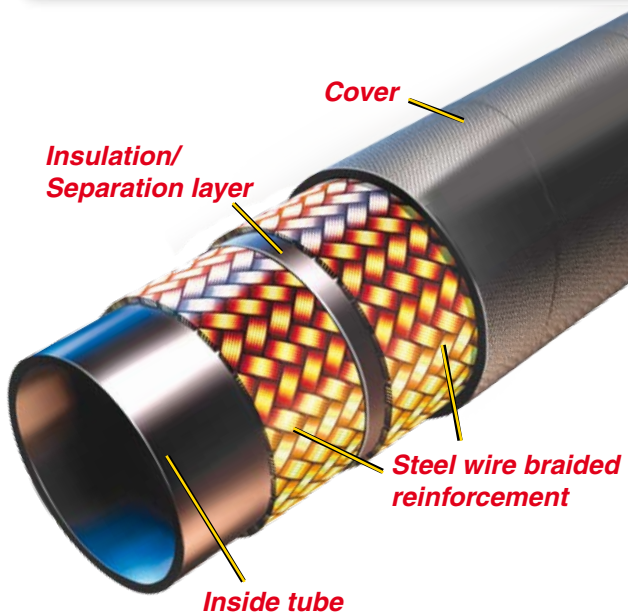

Hose

Typically a rubber hose is constructed of an extruded inside synthetic rubber tube that has the sole purpose to keep the conveyed fluid in the hose. The elastomeric nature of rubber requires that a reinforcement layer be wound or braided around the tube in order to hold the internal pressure. The reinforcement layer(s) are either textile or steel (or both). To protect these inner layers of the hose from the ambient conditions, an outer synthetic rubber cover is extruded around the reinforcement.

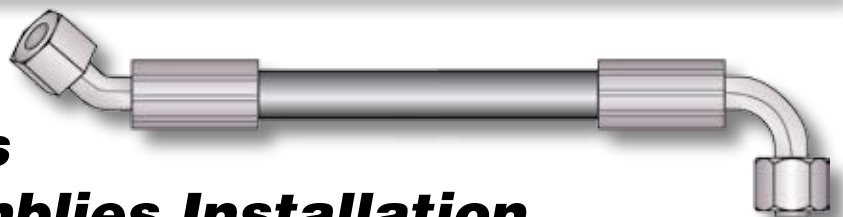

Hose Assemblies Hose Assemblies Installation

The combination of a hose and hose fitting(s) to make a hose assembly, is a critical process that needs to be carried out by professionally trained personnel who follow strict assembly instructions. Improperly assembled hose fittings can separate from the hose and may cause serious injury or property damage from whipping hose, or from fire or explosion of vapor expelled from the hose. (See „Safe Hose Assemblies in 8 Steps“, Page Aa-8)

The hose assembly must be operated within specific limits to maximise a safe and long term service life. These limits are defined in this catalogue and also by both governmental standards and institutional organisation’s and specifications such as the ISO 17165-2, SAE J1273 or EN982.

Working Pressure

Hose and fitting selection must be made so that the published maximum recommended working pressure of the Hose and fitting are equal to, or greater than the maximum system pressure. Surge pressures or peak transient pressures in the system must be below the maximum working pressure of the hose assembly. Surge pressures and peak pressures can usually only be determined by sensitive electrical instrumentation that measures and indicates pressures at milli-second intervals. Mechanical pressure gauges indicate only average pressures and cannot be used to determine surge pressures or peak transient pressures.

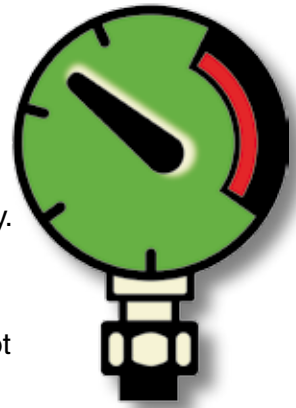

Proof Pressure Test

This test is typically carried out on customer request according to a method defined by the ISO 1402 standard. The test should be made at normal ambient temperature with a proof test bench using water or another suitable liquid. The hose assembly should be pressurised for between 30 to 60 seconds at twice the working pressure of the hose assembly. There should be no leakage or pressure drop. A complete test report should be provided together with the hose assembly to the customer.

Burst Pressure

All hoses in this catalogue have a pressure design factor of 4:1, implying therefore that the burst pressure (hose destruction) is minimum 4 times the published working pressure.

Published burst pressure ratings for hose are for manufacturing test purposes only – burst pressure should **never** play a role in the selection of a hose.

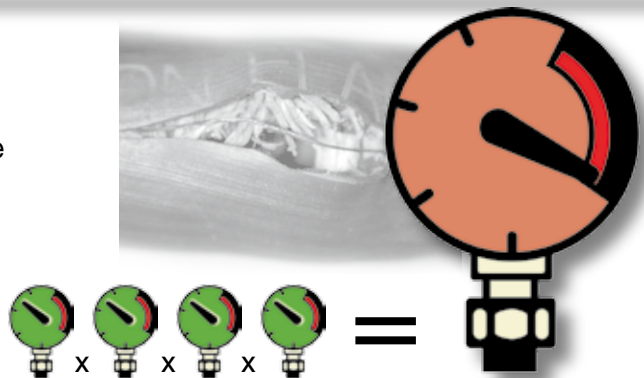

Fluid Compatibility

The hose assembly (hose inner tube, hose outer cover and hose fittings) must be chemically compatible to both the fluid being conveyed by the hose as well as the medium surrounding it. (the chemical resistance table contained in the catalogue, indicates only the resistance of the hose innertube to the respective fluid)

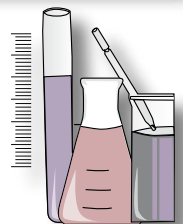

Temperature Range

In order not to negatively effect the properties of the rubber hoses it should be made certain that fluid and ambient temperatures, both steady and transient, do not exceed the limitations of the hose as published in the catalogue. Temperatures below and above the recommended limit will degrade the hose and failure may occur and release fluid.

The mechanical properties of the hose are also influenced by low or high temperatures and should be considered when designing the system.

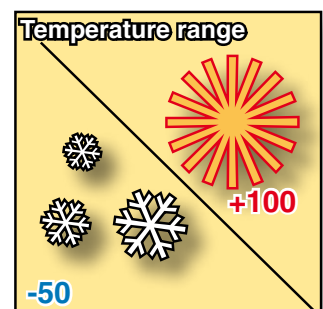

Hose Size

The power transmitted by means of a pressurised fluid varies with pressure and rate of flow.

The size of the components must be adequate to keep pressure drops to a minimum and avoid aging due to heat generation or excessive fluid velocity.

Parker uses the internationally recognised hose dash size as a measurement of the size of their hoses.

This size is a measurement of the inside tube of the hose – not the wall outer diameter.

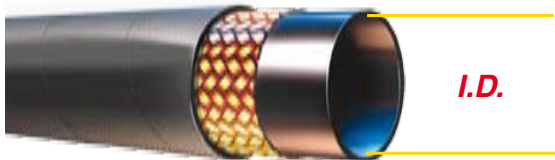

Size	Inch	mm	DN
-6	6/16	$6/16 * 25,4 = 9,525$	10
-6	3/8	9,5	10

Hose Bending Radius

The minimum bend radius of a hose refers to the minimum radius that the hose may be bent through whilst operating at the maximum allowable published working pressure.

Bending radius is not a measurement or indicator of hose flexibility.

The catalogue specified values of bending radii are based on international or Parker specifications and have been proven through rigorous impulse testing of the hose assemblies.

Bending the hose below the minimum bending radius leads to loss of mechanical strength and hence possible hose failure.

A minimum straight length of 1,5 times the hose's outside diameter (D) shall be allowed between the hose fitting and the point at which the bend starts.

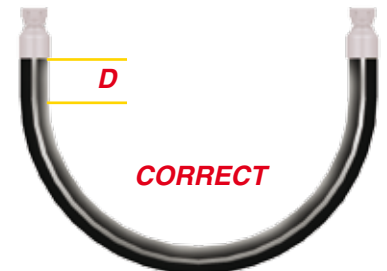
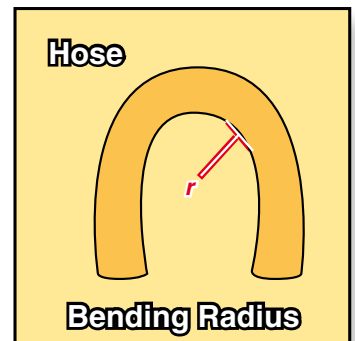

Hose Assembly Routing

The routing of a hose assembly in such a manner so as to avoid any damage to the hose by stretching, compression, kinking or abrasion over sharp edges is essential, to assure maximum service life and safety.

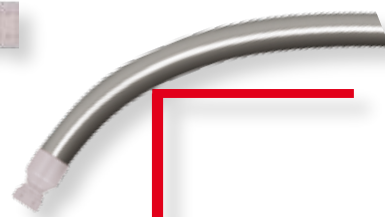

Hose and Fittings Storage

A system of age control should be maintained to ensure that hose is used before its shelf life has expired. Shelf life is the period of time when it is reasonable to expect the hose to retain full capabilities for rendering the intended service. Hose shall be stored in a manner that facilitates age control and first-in, first-out (FIFO) usage based on the manufacturing date on the hose or hose assembly.

The shelf life period of rubber hose in bulk form or hose made from two or more materials (hose assembly) is difficult to define as so many factors can detrimentally influence the hoses suitability for use.

In the German speaking countries the “rules” that must be followed are stated in the DIN 20066:2002-10 and referred to by the general organisation of trade associations (Berufsgenossenschaft) in their actual publication ZH1/74 from April 2005 – safety regulations for hydraulic hose assemblies.

Excerpt DIN 20066:2002-10:

For the production of hose assemblies the hose (bulk hose) must be younger than 4 years according to the hoses date of manufacture. The service life of a hose assembly, including any period of storage should not exceed 6 years; the period of storage should not exceed 2 of these 6 years.

Additionally, the International Standard Organisation (ISO) has prepared a draft version of a guideline for hose/hose assembly usage that differs slightly from the German guideline. The ISO/TR 17165-2 states that the shelf life of hose as bulk hose or as hose made of 2 or more materials should not exceed 40 quarters (10 years) from the date of manufacture of the hose if stored in accordance with ISO 2230.

After all cases of hose storage, if visual inspection gives rise to any doubts as to the functionality of the hose (cracks in the cover, rust etc), pressure testing should be carried out before use or the hose should be disposed of. Hose assemblies should always be considered as safety relevant components, so no risks should be taken.

Hose storage – Best practices:

- Store in a clean, cool and dry area (≈ room temperature)
- Avoid direct sun light or moisture
- Do not store near high power electrical equipment
- Avoid contact with corrosive chemicals
- Avoid Ultraviolet light
- Insects/Rodents
- Radioactive materials



Fittings storage – Best practices:

- Additionally to the factors above the following points should be observed for storage of hose fittings
- Store fittings in clearly marked closed containers such as the original Parker packaging.
- A stock rotation system (FIFO) should be in place so that a shelf life of 2 years is not exceeded for fittings with O-rings as they may degrade as a result of normal environmental conditions, leading to possible system leakages or contamination.

! SAFETY FIRST !

Avoid injury to yourself and others by following these important rules

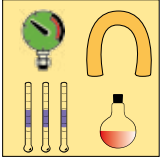

Select proper hose assemblies for the application.

Product choice must be based on published hose specifications and must fit the application requirements. Many factors and conditions affecting the inside and outside of the hose must be taken into account.



Refer to the standards, regulations and directories that apply in the countries where the equipment is sold and used.

Follow hose assembly installation good practice!

Hose must not be stretched, kinked, crushed or twisted during installation or use. Hose must not be bent to less than the minimum bend radius.



Use proper safety protection when manufacturing, testing or installing hose assemblies



Parker Hannifin recommends hose and fitting combinations in this catalog only after completing extensive testing

– only use approved hose and fitting combinations.
– using the Parkrimp hose, fitting and machine concept assures safe hose assemblies!

Parker FluidConnectors **Parkrimp® No-Stive**
Preßmaße - Crimp Dimensions - Sertissage
einzelige Armaturen - for one piece fittings - embouts une pièce

Hose Size (mm)	Inner Diameter (mm)	Outer Diameter (mm)	Wall Thickness (mm)	Material	Part Number
10	8	12	2	316L	10-316L
12	10	14	2	316L	12-316L
15	13	17	2	316L	15-316L
20	18	22	2	316L	20-316L
25	23	27	2	316L	25-316L
30	28	32	2	316L	30-316L
40	38	42	2	316L	40-316L
50	48	52	2	316L	50-316L
63	60	66	3	316L	63-316L
75	72	78	3	316L	75-316L
90	88	94	3	316L	90-316L
100	98	106	4	316L	100-316L
125	124	132	4	316L	125-316L
150	148	156	4	316L	150-316L
200	198	206	4	316L	200-316L
250	248	256	4	316L	250-316L
300	298	306	4	316L	300-316L
400	398	406	4	316L	400-316L
500	498	506	4	316L	500-316L
630	624	632	4	316L	630-316L
750	744	752	4	316L	750-316L
900	894	902	4	316L	900-316L
1000	994	1002	4	316L	1000-316L

Always use up to date Parker crimping tables
– if in doubt contact HPDE@Parker.com

Do not use hydraulic hose to transmit steam

Establish a program of inspections.

Hose assembly must be carried out by trained personnel. Update training regularly.



WARNING – Fluid injection injuries shall be treated without delay and shall not be treated as a simple cut !

- Fluid under pressure can cause serious injury. It can be almost invisible escaping from a pinhole, and it can pierce the skin into the body.
- Do not touch a pressurized hydraulic hose assembly with any part of your body.
- If a fluid-injection accident occurs, medical treatment by a doctor shall be sought immediately.
- Stay out of hazardous areas while testing hose assemblies under pressure. Use proper safety protection.

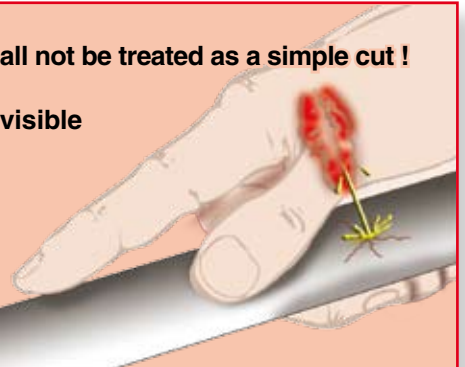

Safe Hose Assemblies in 8 Steps

1 Application

Some applications allow a relatively simple hose selection, eg suction/return lines. Usually however, it is prudent to consider the points below and use them as a guide to help assure all factors have been taken into account. Using the data acquired from considering these points will lead to correct product choice and help assure safety, long service life and optimises the overall cost of the hose assembly.

What is the application of the hose?

- Machine / Equipment type?
- Suction application?
- Working and surge pressures?
- Fluid and/or Ambient temperature?
- Fluid compatibility?
- Non-Conductive Hose Required?

Where will the hose be used?

- Environmental conditions?
- Minimum bend radius?
- Routing requirements? /Clamps, protection sleeves?
- Is the hose exposed excessive abrasion?
- Is the hose subject to Mechanical Loads?

Need to meet national, legal, industry or customer Standards?

- Thread Type? / Does the thread type withstand the system pressure?
- Specific hose construction prescribed?

2 Size

The power transmitted by means of a pressurised fluid varies with pressure and rate of flow. The size of the components (hose and fittings) must be adequate to keep pressure drops to a minimum and avoid damage due to heat generation or excessive fluid velocity.

If the required size of hose is not already known, the **Hose Capacity Nomogram** on Page Ab-14, may assist.

The size of standard hoses is specified by the inside diameter of the tube.

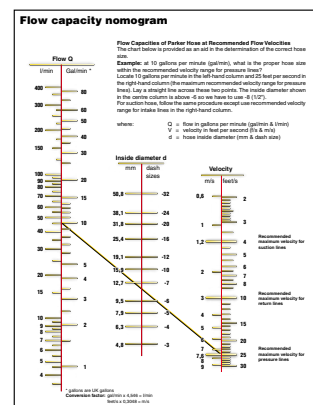
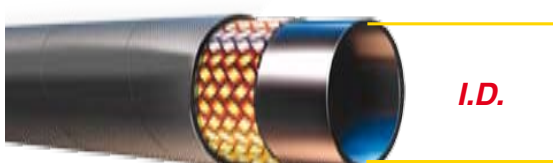

3 Pressure

Hose and fitting selection must be made so that the maximum recommended working pressure of the hose assembly is equal to or greater than the maximum system pressure. Surge pressures or peak pressures must be below this maximum working pressure.

Throughout the catalogue the pressures are specified in Mega Pascals.
 eg. 27,6 Mpa = 276 bar = 4000 psi
 (A full conversion table for other units of measurement can be found on Page Ab-12)

After defining the size of hose required the Hose Selection Overview table on Page Ab-2 can be used to select the appropriate hose(s).

This table provides a quick reference showing the hose types offered in the catalogue, their temperature rating, their construction and the specification to which they adhere.

	Unit	SI Unit	Conversion Unit	Factor
Length	1 foot	m	metre	0.3048
	1 metre	mm	mm	1000.0000
	1 foot	in	in	12.0000
Area	1 square inch	mm ²	mm ²	645.16
	1 square centimetre	mm ²	sq. in.	0.1550
	1 gallon (US)	gal	l	4.54609
Volume	1 litre	l	gal (US)	0.264172
	1 gallon (US)	gal	l	3.78533
	1 litre	l	gal (UK)	0.220469
Weight	1 pound	kg	kg	0.453592
	1 kilogramme	kg	lb	2.20462
	1 pound force	kg + m	kg + m	1.48946
Torque	1 foot-pound	kg + m	kg + m	1.35582
	1 foot-pound force	kg + m	kg + m	1.35582
	1 pound per square inch	psi	bar	0.06895
Pressure	1 bar	bar	psi	14.5038
	1 pound per square inch	psi	MPa	0.0000689
	1 kilopascal	kPa	bar	0.01
Velocity	1 bar	bar	MPa	100
	1 kilopascal	kPa	bar	0.1
	1 bar	bar	MPa	0.1
Flow rate	1 foot per second	ft/s	m/s	0.3048
	1 metre per second	m/s	ft/s	3.28084
	1 gallon per minute (US)	gal/min	l/min	4.54609
Temperature	1 litre per minute	l/min	gal/min (US)	0.264172
	1 gallon per minute (US)	gal/min	l/min	3.78533
	1 litre per minute	l/min	gal/min (UK)	0.220469
Temperature	Fahrenheit degree	°F	°C	5/9 * (°F - 32)
	Celsius degree	°C	°F	°C * 9/5 + 32

Hose fitting's pressure rating

This is a subject often neglected by both designers and producers of hose assemblies alike. The pressure rating of a hose assembly is determined by the pressure rating of the component in the hose assembly with the lowest working pressure.

Considering therefore only the pressure rating of the hose is NOT enough! Quite often the pressure rating of the fittings can lie below that of the hose; so to avoid any safety risks caused by non-compatibility of the fittings for the desired system pressure rating, the maximum working pressures of the Parker fittings in this catalogue can be found in Page Ab-3.

4 Temperature

The temperature of the fluid in the hose and the ambient temperature around the hose in combination with the medium of both the conveyed fluid and the environment, need to be carefully considered in the hose selection process. The temperatures in the catalogue refer to the temperatures of the fluid in the hose.

High Temperature

In general the combination of high temperatures and high pressures reduce the service life of the hose. More regular inspection of the hose assemblies should be carried out to assure the continued safe functionality of the hose assembly. If the outer cover is brittle or cracked, the hose assembly should be replaced.

To maximise hose service life choose Parker high temperature hoses with part numbers ending with 6, eg 436 - SAE 100 R16 high temperature hose.

Low Temperatures

In general cold temperatures reduce the flexibility of rubber products. The minimum specified temperature designates the minimum temperature that the hose may be subjected to before, during a cold-bending test, visible cracks appear in the rubber hose cover.

For extremely low temperatures Parker LT products should be selected, eg. 461LT – EN857-2SC Low Temperature hose

5 Fluid Compatibility

It is vital for long service life and leak free functionality that the hose assembly (hose inner tube, hose outer cover and hose fittings and O-rings) be chemically compatible to both the fluid being conveyed through the hose as well as the environment of the hose. (The chemical resistance table contained in the catalogue, indicates only the resistance of the hose innertube to the respective fluid)

Page Ab-16 shows a comprehensive chemical compatibility table for the Hose Products Division’s hoses.

Should the table not contain the required chemical compatibility information required, please contact Parker by email using HPDE@Parker.com

6 Hose Fittings

Hose ends, or hose fittings as commonly named, tend to be specified by the machine port that the hose is to be attached to and are heavily influenced by the country of origin. Despite many efforts being made to standardise and rationalise connection types, many connection systems still exist due to national or international standards or even specific to a customer or a market segment. In general there are five main fittings systems generally used for hydraulic connections today, whereby the overall list is much longer.

- European Thread Types:**
- German – (DIN)
 - British – (BSP)
 - French – (GAS & Metric)
 - North American – (SAE)
 - Japanese – (JIS)

In order to assure a long service life and leak free running of the system the fitting style and the sealing type of the fitting should be considered in the design process.

Safety First !!

Hose / Hose Fitting Compatibility

Parker undertakes intensive testing of the hoses and fittings to assure that the respective Parker fittings series is compatible with the designated hose, as shown in the catalogue. Parker take no responsibility to assure that hose from another manufacturer is compatible with Parker hose fittings, nor does Parker take responsibility for other manufacturers fittings compatibility with Parker hose.

Identifying Fitting Types

In general fittings can be identified by their visual appearance, their sealing surface/ sealing type or by their thread type/form. On page Ab-26, there is a comprehensive fitting identification guide that will help both identification of the thread and the sealing mechanism.

7 Hose Assembly Manufacture

! Parker representatives can support you with training or advice !

Cutting and hose length

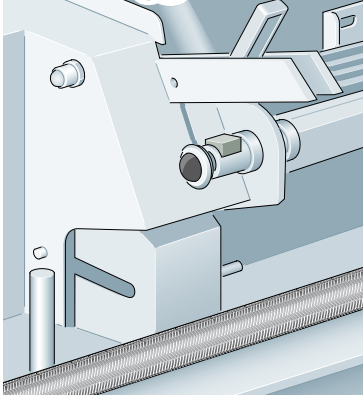

Hose is cut to the desired length according to specifications.

The correct hose cutting tool ensures a square, clean cut without damaging the pressure reinforcement. Depending on the hose type, different kinds of blades must be used: 1) smooth blade, 2) scolloped blade

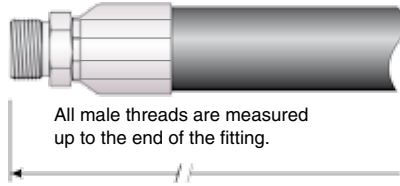

All male threads are measured up to the end of the fitting.

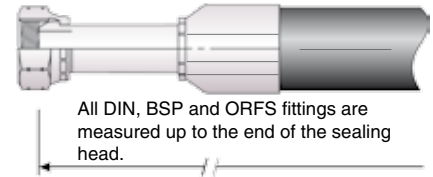

All DIN, BSP and ORFS fittings are measured up to the end of the sealing head.

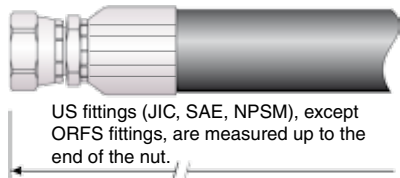

US fittings (JIC, SAE, NPSM), except ORFS fittings, are measured up to the end of the nut.

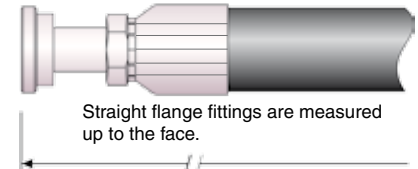

Straight flange fittings are measured up to the face.

Tolerances for hose assemblies

Length tolerance according to DIN 20066:2002-10 and EN 853 to EN 857

Hose assembly length	up to DN25	from DN32	from DN60
	(size -16)	(size -20) up to DN50 (size -32)	(size -40)
up to 630	+7 -3	+12 -4	+25 -6
over 630 up to 1250	+12 -4	+20 -6	
over 1250 up to 2500	+20 -6	+25 -6	+1,5 % -0,5 %
over 2500 up to 8000		+1,5 % -0,5 %	
over 8000		+3 % -1 %	

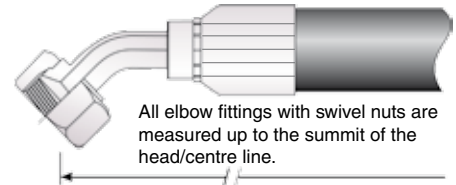

All elbow fittings with swivel nuts are measured up to the summit of the head/centre line.

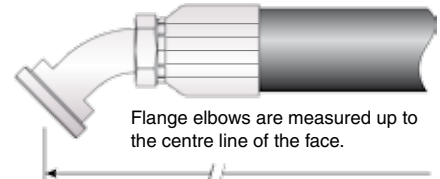

Flange elbows are measured up to the centre line of the face.

Marking

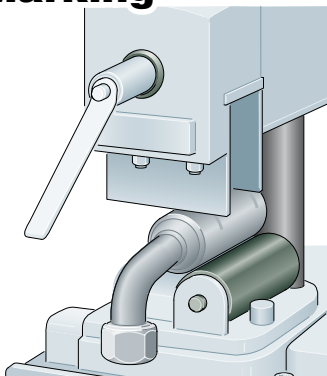

According to EN and ISO standards, hose assemblies must be clearly and permanently marked.

They must bear the following informations:

- manufacturer's identification
- date of production (year and month)
- maximum permissible working pressure limit of hose assembly

Crimping

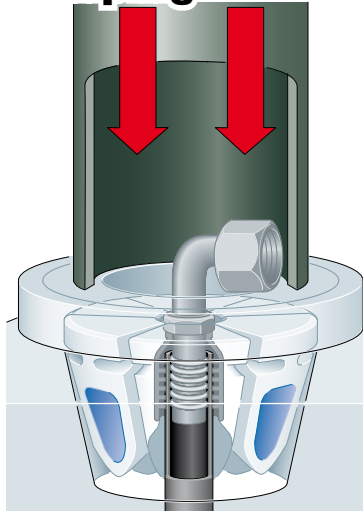

Crimping is the safest, fastest and most commonly used method of making a hose assembly. The Parker crimping systems ensure precise, leak-free and tear-proof assembly of hose and fitting. Reaching the exact crimping diameter is possible with Parkrimp crimping tools or freely adjustable crimping tools.

When crimping, it is essential that hose, fitting and crimping tool (dies) match precisely (see Parker crimping tables on pages Ed-1 -Ed-10). Furthermore, the insertion depth, a square cut hose, correct, burr-free and clean crimping are important to ensure a correctly formed and leak-free connection of hose and fitting. Using the ParKrimp hose crimpers or free adjustable crimpers, the fitting is crimped onto the hose in one slow and smooth crimping procedure. A depth stop with automatic function ensures safe positioning of the fitting. This guarantees the correct crimping of hydraulic hose assemblies.

26, 46, 48, 70, 71, 73, 78, 79, S6 series:

Push the hose all the way into the coupling. Place the hose next to the fitting shell and mark the insertion depth or the length of the fitting onto the hose – (lubricate hose end if necessary) push hose into the fitting until the mark on the hose is even with the end of the shell.

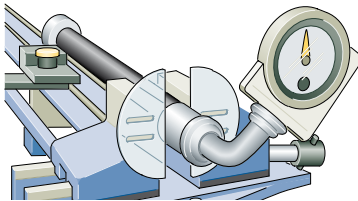
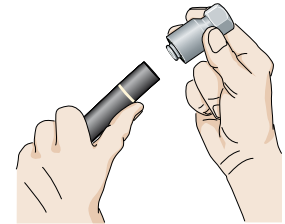

Angle setting

The displacement angle of a hose assembly is indicated only when two elbow fittings are assembled in a displaced way.

The angle always has to be indicated clockwise looking from the elbow fitting at the back to the one in the front. Please also consider the natural bending of the hose.

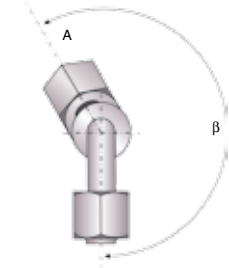

Testing

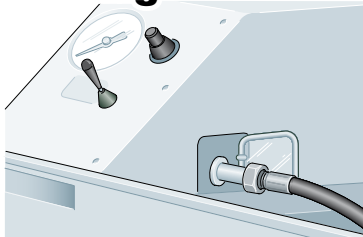

Static test pressure depending on the hose type and application is applied to the finished hose assembly for a pre-defined period of time. The test procedure can be documented using a test logging unit. The test pressure for Parker hydraulic hose assemblies is 2 times the value of the dynamic operating overpressure.

Proof Pressure Test – This test is typically carried on customer request according to a method defined by the ISO 1402 standard. The test should be made at normal ambient temperature with a proof test bench using water or another suitable liquid. The hose assembly should be pressurised for between 30 to 60 seconds at twice the working pressure of the hose assembly. There should be no leakage or pressure drop. A complete test report should be provided together with the hose assembly to the customer.

Cleaning

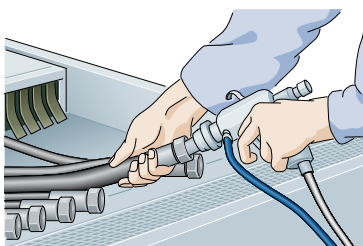

The hydraulic systems have to reach a defined degree of cleanliness. For this purpose we use cleaning devices which ensure fast and efficient cleaning of hose assemblies. With the TH6-6 standard cleaning device, cleanliness class 17/14 according to ISO 4406 can be achieved. For higher degrees of cleanliness, the TH6-6 device needs to be equipped with a different filter cartridge (see chart). This cleaning device first washes the hose assembly with a detergent and an anticorrosive agent and then blows it out with pressurised air. For permanent protection of the finished hose assembly against impurities we recommend using plastic caps.

ISO 4406	NAS 1638	SAE 749	Cartridge
11/8	2		
12/9	3	0	
13/10	4	1	
14/11	5	2	
15/12	6	3	
16/13	7	4	3 μ
17/14	8	5	3 μ
18/15	9	6	3 μ
19/16	10		3 μ
20/17	11		
21/18	12		

According to EN 982, hose assemblies are not permitted to be manufactured from any components that have already been in use in other hose assemblies.

8 Routing / Installation / Environmental Influences

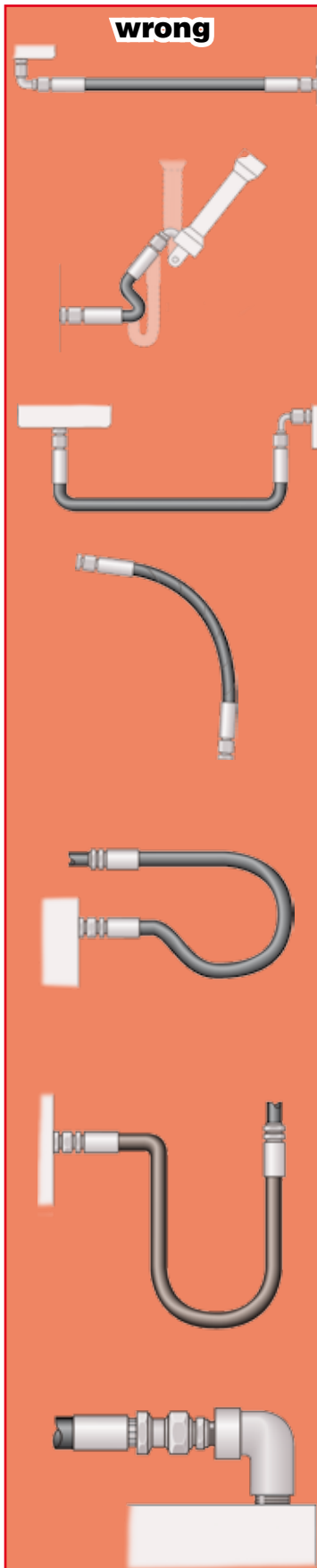

The **routing** of the hose assembly and the environment in which the hose assembly operates directly influence the service life of the hose assembly. The following diagrams indicate the correct routing of hose assemblies that will maximise its service life and assure a safe working functionality.

When hose installation is straight, it must be assured that there is enough slack in the hose to allow for changes in length that occur when pressure is applied. When pressurized, hose that is too short may pull loose from its hose fittings or stress the hose fitting connections, causing premature metallic or seal failures.

The **hose length** must be determined so that the hose assembly has enough slack to allow the system components to move or vibrate without creating tension in the hose.

However, care needs to be taken not to allow too much slack and therefore introduce the risk of the hose snagging on other equipment or rubbing on other components.

Mechanical straining of the hoses needs to be avoided, so the hose must not be bent below its minimum bending radius or twisted during installation. The minimum bending radii for each hose is stated in the hose tables in the catalogue.

The plane of movement must also be considered and the hose routing selected accordingly.

Hose routing also plays an important role on the selection of the hose fittings, as the correct fittings can avoid straining the hoses, unnecessary hose length or multiple threaded joints.

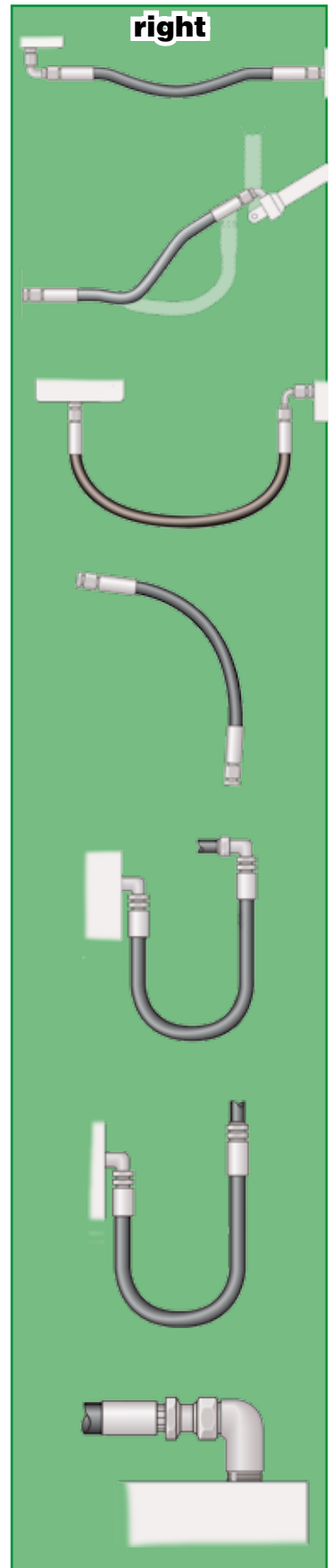

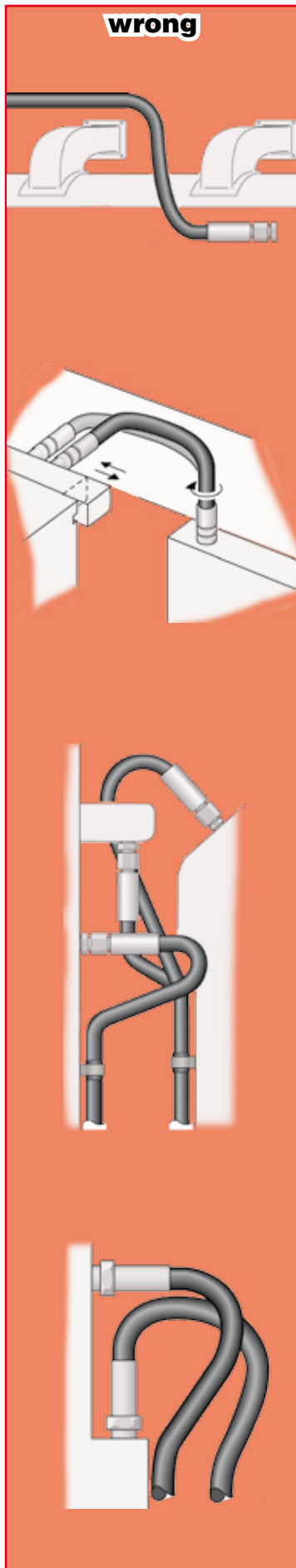

wrong

Correct clamping (holding/supporting) of the hose should be exercised to securely route the hose or to avoid the hose contacting surfaces that will cause the hose damage.

It is however, vital that the hose be allowed to keep its functionality as a “flexible-pipe” and not be restricted from changing in length when under pressure.

It should also be noted that hoses for high- and low-pressure lines shall not be crossed or clamped together, as the difference in changes in length could wear the hose covers.

Hose should not be bent in more than one plane. If hose follows a compound bend, it shall be coupled into separate segments or clamped into segments that each flex in only one plane.

Hoses should be kept away from hot parts as high ambient temperatures shorten hose life. Protective insulation may need to be used in unusually high ambient temperature areas.

Whilst the importance of the functionality is prime the aesthetics and practicality of the installation should also be considered in the design. It should be considered that maintenance might be necessary at some stage in the future, so prohibitive design routings should be avoided.

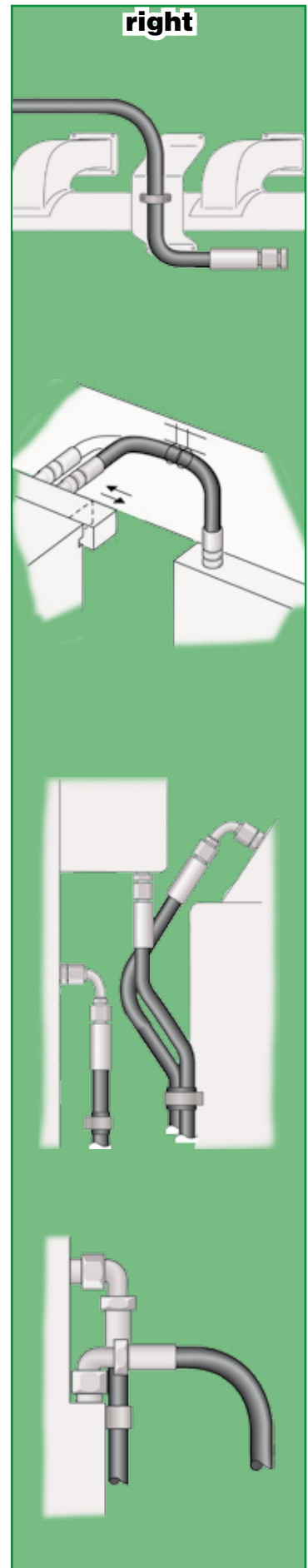

right

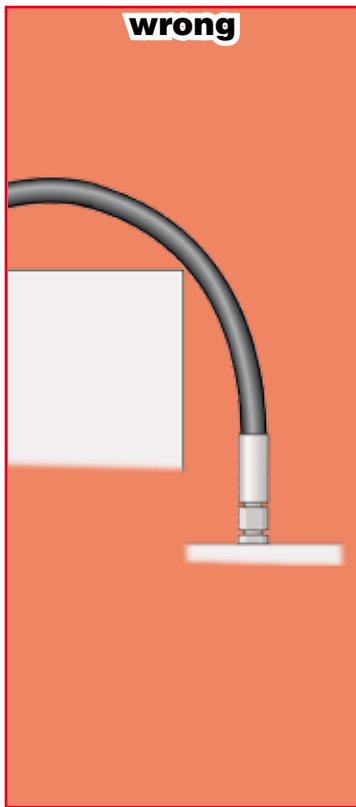

Abrasive influences

In general care should be taken that the hose is not exposed to direct surface contact that will cause abrasive wearing of the outer cover (either hose to object or hose to hose contact). If however, the application is such that this cannot be avoided, either a hose with a higher abrasion resistant hose cover or a protective sleeve need to be used.

Parker **TOUGH COVER** (TC) or **SUPER TOUGH** (ST) covers offer 80 times or respectively 1000 times the abrasion resistance of standard rubber covers.

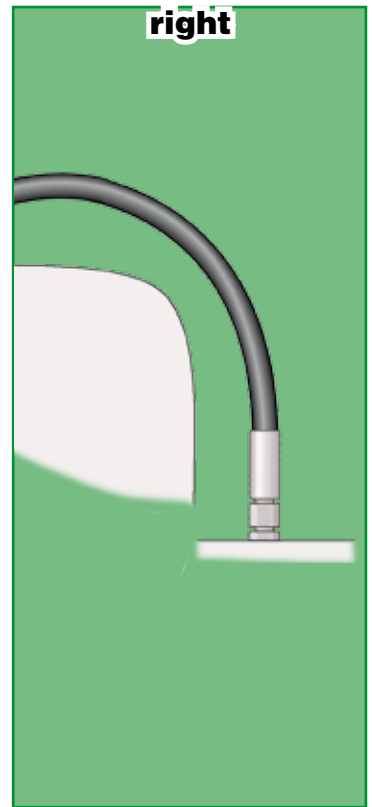

Pollution of hydraulic circuits

Modern hydraulic equipment is becoming highly precise and as such more sensitive, so as a result the importance of a clean working fluid in the system is growing. Because as many as 75% of hydraulic system failures are caused by contamination of the fluid by solid particles, the initial cleanliness of hydraulic components, as the main source of these contaminants, is vital.

With hose assemblies most of the pollution/contaminates enter the hose assembly during its production and mainly during the cutting (or skiving) process.

In order to avoid system failures, all hose assemblies should be cleaned before use (cleaned and plugged before shipping) with suitable cleaning equipment such as the Parker TH6-6 machine. This cleaning device first washes the hose assembly with a detergent and an anticorrosive agent and then blows it out with pressurized air.

The level of contamination is defined in three popular norms: ISO4406, ISO4405 or NAS 1638. Most common however, is the ISO 4406, which describes the number and size of solid particles in the hydraulic system by means of a classification value e.g. 16/13.

With the Cleaning Machine TH6-6 you can reach the following classification values when using the 3 microns filter cartridge

ISO 4406	NAS 1638	SAE 749	Cartridge
11/8	2		
12/9	3	0	
13/10	4	1	
14/11	5	2	
15/12	6	3	
16/13	7	4	3 μ
17/14	8	5	3 μ
18/15	9	6	3 μ
19/16	10		3 μ
20/17	11		
21/18	12		



How to Order

To make ordering Parker products easier, we have itemized the order numbers on this page. This will be especially helpful when you order hose assemblies. You can find further useful hints on the following page.

1. Hose

Example: **436-6**

436-6 > Hose type

436-6 > Hose **inside diameter** in size

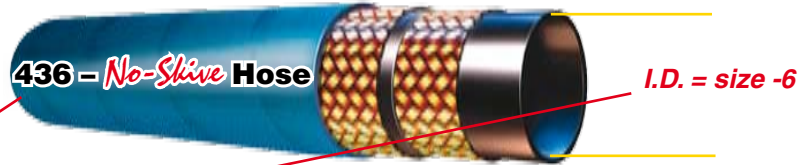

2. Hose Fittings

Example: **1 CA 48 12-6**

1 CA 48 12-6 > Fitting

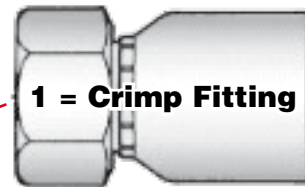

1 CA 48 12-6 > End configuration nomenclature

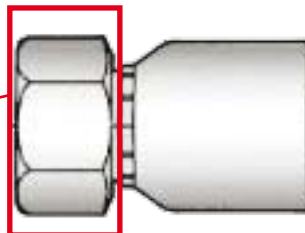

1 CA 48 12-6 > Parker Fitting series

1 CA 48 12-6 > Thread or Tube size

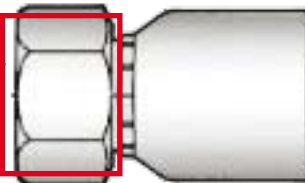

1 CA 48 12-6 > Hose size and hose fitting size

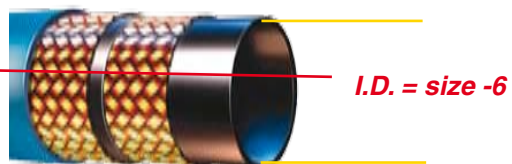

Material/ specification:

- Without suffix: steel, zinc plated
- B: brass
- C: stainless steel
- K: without a plastic ring
- SM: metric hexagon dimension

The content of the hose crimping tables shows the standard part numbers. For the availability of non standard parts/materials please contact your local Parker service centre. All part numbers printed in bold in the respective price list are available ex-stock.

3. Hose Assemblies

Example: **P436CACF12106-1000-0-SG900**

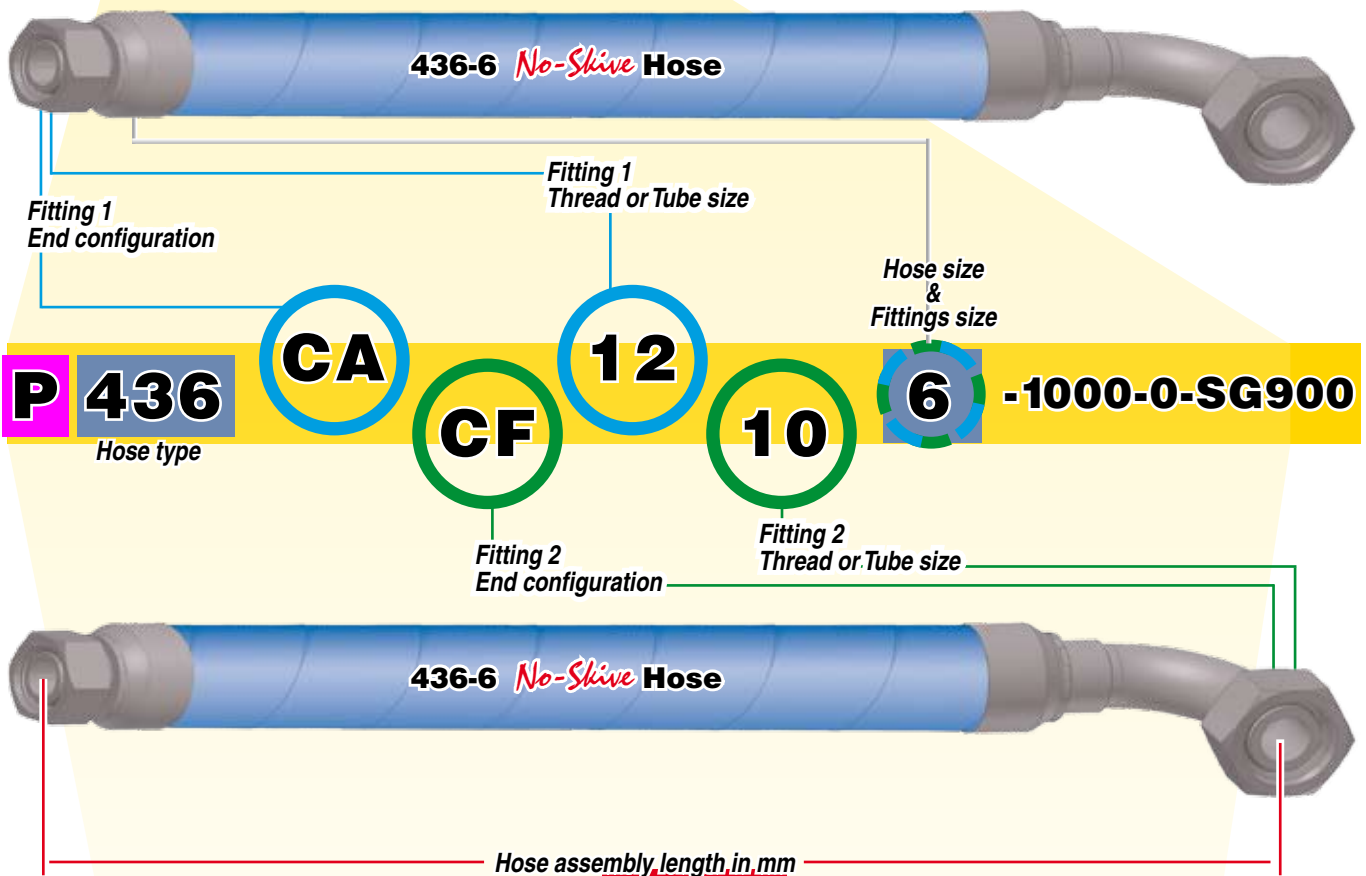

P436CACF12106-1000-0-SG900

D = Parkrimp *No-Skive* Fittings Series 46
 F = Parkrimp *No-Skive* Fittings Series 70, 71, 73, 78, 79 and S6
 P = Parkrimp *No-Skive* Fittings Series 48
 R = Low Pressure Push-Lok Fittings Series 82

Accessory,
 e.g. spring guard 900 mm length

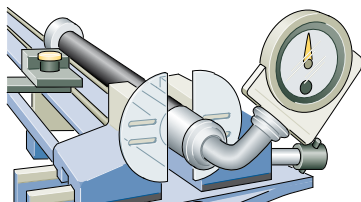

Displacement angle is relevant when the hose assembly has bent fittings



SG	Spring Guard
AG	Armour Guard
AS/PS	Partek Nylon protective sleeve
FS	Fire Sleeves
HG	PolyGuard-Hose Protector
PG	Parkoil-Hose Protector

Explanation of the example

Hose assembly with hose 436 in size -6 and fitting series 48. Hose assembly length 1000 mm.

Fitting 1: end configuration CA has a 12 mm pipe diameter and has a size -6 hose nipple

Fitting 2: end configuration CF has a 10 mm pipe diameter and has a size -6 hose nipple

The displacement angle for this combination is 0 degree. On request a displacement angle can be specified for the bent fitting in relation with the hose curvature. A protection sleeve as a Spring Guard in length 900 mm is on the hose assembly.

Technical Data

Hose Overview	Ab-2
Hose Fittings Pressure Ratings	Ab-3
Hose Fittings Overview	Ab-4–Ab-5
Hose Fitting Nomenclature	Ab-6–Ab-9
Classification Body Type Approvals	Ab-10–Ab-11
Conversion Chart	Ab-12
Temperature / Pressure Chart	Ab-13
Flow Capacity Nomogram	Ab-14
The Correct Method to Fit Female Swivel Ends	Ab-15
Chemical Resistance Table	Ab-16–Ab-21
Safety Guide	Ab-22–Ab-25
Identifying Fitting Types	Ab-26–Ab-35

Hose Fittings Pressure Ratings

Fitting end connection	Description	Metric tube size in mm									
		Maximum working pressure (MPa) – safety factor 4:1									
		4	5	6	8	10	12	16	20	24	32
92, B1, B2, B4, B5	BSP swivel female	63,0		55,0	43,0	37,5	35,0	28,0	25,0	21,0	21,0
EA, EB, EC	BSP swivel female with O-ring	40,0		40,0	35,0	35,0	31,5	25,0	20,0	16,0	12,5
91, D9	BSP male	63,0		55,0	43,0		35,0	28,0	25,0	21,0	21,0
01	NPTF male	34,5		27,5	24,0		21,0	17,0	15,0	14,0	14,0
02	NPTF female	34,5		27,5	24,0		21,0	17,0	15,0	14,0	14,0
03, 33	SAE (JIC) 37° male	41,0	41,0	34,5	34,5	34,5	34,5	27,5	20,0	17,0	17,0
04	SAE 45° male	41,0	41,0	34,5	34,5	34,5	34,5	27,5	20,0	17,0	17,0
05	SAE male with O-ring	41,0	41,0	34,5	34,5	34,5	34,5	27,5	20,0	17,0	17,0
06/68,37/3V, 39/3W, L9, 41/3Y	SAE (JIC) 37° swivel female	41,0	41,0	34,5	34,5	34,5	34,5	27,5	20,0	17,0	17,0
93	Female SAE (JIC) 37° 90° Elbow	41,4	41,0	34,5	34,5	34,5	34,5	27,5	20,0	17,0	17,0
07	Female NPSM-pipe swivel	34,5		27,5	24,0		21,0	17,0			
08, 77, 79	Female SAE 45° swivel	41,0	41,0	34,5	34,5	34,5	34,5	27,5	20,0	17,0	17,0
1L	Male NPTF pipe swivel 90° Elbow	21,0	21,0	21,0	21,0	19,0	15,5	14,0	11,0	9,0	8,0
S2	Female NPTF pipe swivel	21,0	21,0	21,0	21,0	19,0	15,5	14,0	11,0	9,0	8,0
0G, 0L	Male SAE O-Ring	21,0	21,0	21,0	21,0	19,0	15,5	14,0	11,0	9,0	8,0
28, 67, 69	SAE Male inverted 45° swivel	19,0	17,0	15,0	14,0						
15, 16, 17, 18, 19, 26, 27, 89	SAE flange Code 61				34,5	34,5	34,5	34,5	27,5	21,0	21,0
4A, 4N, 4F	SAE flange 5000 psi								34,5	34,5	34,5
6A, 6E, 6F, 6G, 6N, XA, XF, XG, XN	SAE flange Code 62 6000 psi				41,0		41,0	41,0	41,0	41,0	41,0

Fitting end connection	Description	Metric tube size in mm									
		Maximum working pressure (MPa) – safety factor 4:1									
		4	5	6	8	10	12	16	20	24	32
JM, J6, J8, J0, JU	ORFS male	41,0		41,0	41,0	41,0	41,0	41,0	27,5	27,5	
JC, JS, J3, J7, J9, J5, J1	ORFS swivel female	41,0		41,0	41,0	41,0	41,0	41,0	27,5	27,5	
JD	Male ORFS Bulkhead with Locknut with O-ring	41,0		41,0	41,0	41,0	41,0	41,0	27,5	27,5	
GU	JIS / BSP swivel female 60° cone	35,0	35,0	35,0	35,0	28,0	28,0	21,0	17,5		
FU	Female JIS / BSP 30° parallel pipe swivel	35,0	35,0	35,0	35,0	28,0	28,0	21,0	17,5		
MU	JIS 30° metric swivel female	35,0	35,0	35,0	35,0	28,0	28,0	21,0	17,5		
MZ	Metric swivel female 90° Elbow	35,0	35,0	35,0	35,0	28,0	28,0	21,0	17,5		
UT	JIS / BSP male 60° cone	35,0		35,0	35,0		28,0	21,0	17,5		
V1	Banjo soft seal with UNF bolt	25,0	25,0		21,5	21,5	20,0				
V3	Banjo soft seal with BSPP bolt	25,0	25,0		21,5	21,5	20,0				

Fitting end connection	Description	Metric tube size in mm • Light series – L									
		Maximum working pressure (MPa) – safety factor 4:1									
		6	8	10	12	15	18	22	28	35	42
C3, C4, C5	DIN 20078 swivel female Form A	25,0	25,0	25,0	25,0	25,0	16,0	16,0	10,0	10,0	10,0
CA, CE, CF	DIN 20066:2002-10 swivel female with O-ring, Form N	31,5	42,5	40,0	35,0	31,5	31,5	28,0	21,0	16,0	16,0
DO, DF DG, DK	DIN 20066:2002-10 male stud, Form D	25,0	42,5	40,0	35,0	31,0	28,0	28,0	21,0	16,0	16,0
DX	Metric swivel female with O-ring	31,5	42,5	40,0	35,0	31,5	31,5	28,0	21,0	16,0	16,0
1D, DD 5D	Metric standpipe	25,0	25,0	25,0	25,0	25,0	16,0	16,0	10,0	10,0	10,0
CW, NW	High pressure cleaning hose connection					40,0					
PW	High pressure cleaning hose connection			22,5							

Fitting end connection	Description	Metric tube size in mm • Very light series – LL									
		Maximum working pressure (MPa) – safety factor 4:1									
		8	10	12	15	18	22	28	35	42	50
C0	DIN 20066:2002-10 swivel female DKLL						6,3	6,3	6,3	6,3	4,0











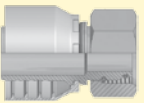
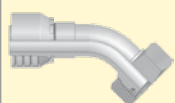

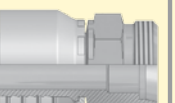

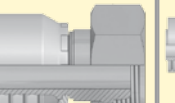

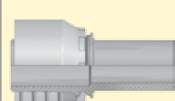
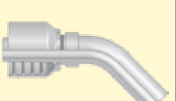

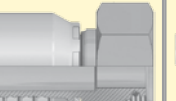

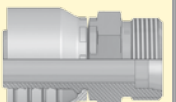
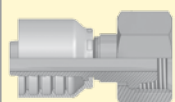
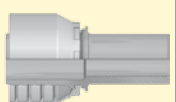
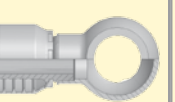





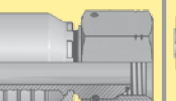

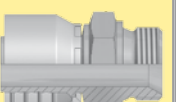
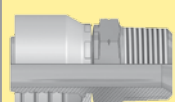
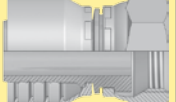
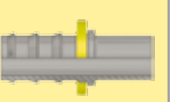
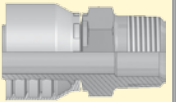
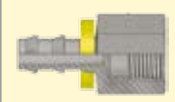
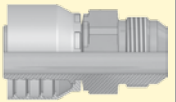
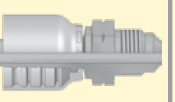
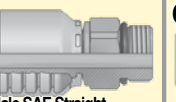
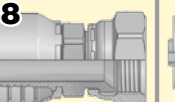
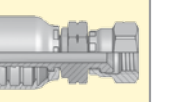
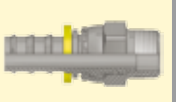
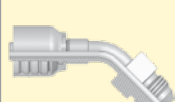

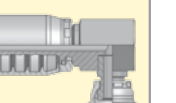
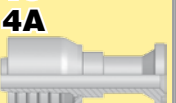
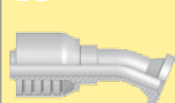

Fitting end connection	Description	Metric tube size in mm • Metric										
		Maximum working pressure (MPa) – safety factor 4:1										
		6	8	10	12	14	16	18	20	22	25	27
49	Banjo Union (DIN 7642)	20,0	20,0	20,0	20,0	20,0	20,0	20,0	20,0	20,0	20,0	
V2	Banjo soft seal with metric bolt				25,0	25,0		21,5		21,5		20,0





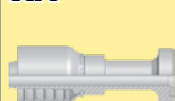



Fitting end connection	Description	Metric tube size in mm • Heavy series – S										
		Maximum working pressure (MPa) – safety factor 4:1										
		6	8	10	12	14	16	20	25	30	38	
C6, C7, C8	Swivel female	63,0	63,0	63,0	63,0	63,0	40,0	40,0	40,0	25,0	25,0	
C9, 0C, 1C	Swivel female DIN 20066:2002-10 with O-ring, Form P	63,0	63,0	63,0	63,0	63,0	42,0	42,0	42,0	42,0	42,0	
D2	Male stud	63,0	63,0	63,0	63,0	63,0	42,0	42,0	42,0	42,0	42,0	
3D	Metric standpipe	63,0	63,0	63,0	63,0	63,0	40,0	40,0	40,0	25,0	25,0	

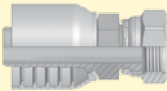
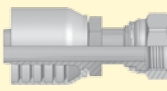
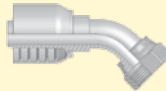
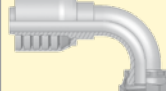

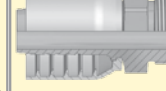

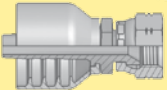
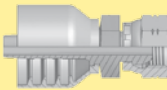
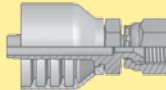

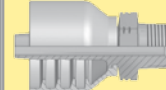
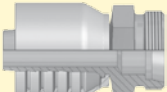

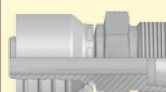
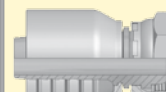
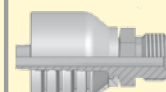
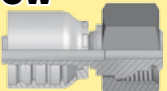
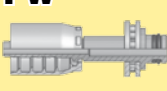
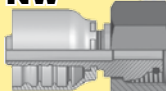

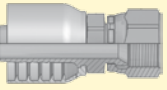

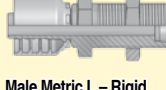
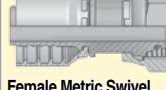

Fitting end connection	Description	Metric tube size in mm • French gas series				
		Maximum working pressure (MPa) – safety factor 4:1				
		13	17	21	27	33
F2	Swivel female 90° Elbow	36,0	27,0	25,5	20,0	17,0
F4	Swivel female (Ball Nose)	36,0	27,0	25,5	20,0	17,0
FG	Male stud	36,0	27,0	25,5	20,0	17,0
GE	Metric standpipe	36,0	27,0	25,5	20,0	17,0

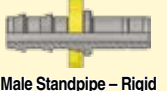
Fitting end connection	Description	Metric tube size in mm • French metric series						
		Maximum working pressure (MPa) – safety factor 4:1						
		10	12	14	18	20	22	30
F9	Swivel female	20,0		14,0	16,0	14,0	13,0	12,2
F6	Male agricultural valves	20,0		14,0	16,0	14,0	13,0	12,2
FA	Male agricultural valves		25,0					

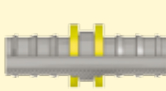
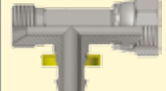
Hose Fittings Overview

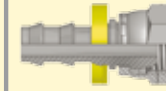
DIN	CA  DKOL	CE  DKOL 45°	CF  DKOL 90°	DO  DKM or DKLL	C0  Female Metric Series LL Swivel (Ball Nose)	C3  DKL	C4  DKL 45°
	C5  DKL 90°	1D  BEL	DD  BEL 45°	5D  BEL 90°	C9  DKOS	0C  DKOS 45°	1C  DKOS 90°
	D2  CES	C6  DKS	3D  BES	49  Metric Banjo	9B  Swivel Female 45° Elbow	9C  Swivel Female 90° Elbow	
	92  DKR	B1  DKR 45	B2  DKR 90	B4  DKR 90 (Compact)	EA  DKOR	EB  DKOR 45°	EC  DKOR 90°
	D9  AGR	91  AGR-K	B5  Female BSP Parallel Pipe - Swivel (Flat Seat)	34  Standpipe			
	01  AGN	02  Female NPTF Pipe Rigid - Straight	03  AGJ	04  Male SAE 45° - Rigid	05  Male SAE Straight Thread with O-Ring - Rigid	06 68  DKJ	08  AGS
13  Male NPTF Pipe Swivel	33  Male JIC 37° - Rigid	37 3V  DKJ 45°	39 3W  DKJ 90°	41 3Y  DKJ 90°L	L9  DKJ 90° M	93  Female JIC 37° - Swivel (Block Type)	
15 4A  SFL	16  SFL 22.5	17 4F  SFL 45°	19 4N  SFL 90	6A  SFS	6F  SFS 45°	6N  SFS 90°	
89  SFL 90 - long	XA  Caterpillar Flange Head	XF  Caterpillar Flange Head 45°	XG  Caterpillar Flange Head 60°	XN  Caterpillar Flange Head 90°			

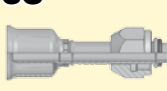
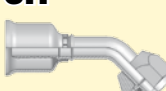
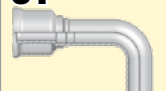
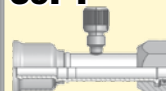
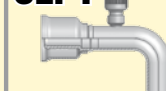
ORFS	JC  ORFS - short	JS  ORFS - long	J7  ORFS 45°	J9  ORFS Female 90	J1  ORFS - extra long	J5  ORFS 90 - long	JM  ORFS Male
	JD  Male ORFS – Bulkhead with Locknut (with O-Ring)						
JIS	FU  GUI	GU  GUO	MU  Female Metric Swivel – (30° Flare)	MZ  Female Metric Swivel – (30° Flare)	UT  Male BSP Taper Pipe Rigid – (60° Cone)		
	French Standard	FG  Male Rigid Gas Series - (24° Cone)	F2  Female Swivel Gas Series	F4  Female Swivel Gas Series - (Ball Nose)	F6  Male Metric (24° Cone)	F9  Swivel Female Metric (Ball Nose)	FA  Metric Male for Agriculture Valves
High Pressure Cleaning		CW  Power Cleaner Connection	PW  Male Kärcher Metric Cleaning Hose Fitting – Rigid	NW  Female Kärcher Metric Cleaning Hose Fitting Swivel – (New Design)			

others	XU  Female Metric Swivel – (30° Flare)	XY  Female Metric Swivel – (30° Flare)	DK  Male Metric L – Rigid Bulkhead with Locknut (24° Cone)	DX  Female Metric Swivel (M27x2) O-Ring – Light Series	FF  Metru-Lok Swivel Female	AF  Male BSP Parallel Pipe Rigid – Straight (with O-Ring Seal)	NM  Male BSP Parallel Pipe – L Series – Rigid Straight – ED-Seal
	YW  Male Standpipe – Rigid – Straight – A-Lok	VW121  BSP Swivel Female	82  Push-Lok Union	DP  Metric Swivel Female Tee / Male Stud	DR  Metric Swivel Female Tee	5C  60° Cone Swivel Female	6C  60° Cone Swivel Female – 45° Elbow
	7C  60° Cone Swivel Female – 90° Elbow	5S  Female Tube O-Ring Swivel – Short Pilot	5H  Female Tube O-Ring Swivel – 45° Elbow Short Pilot	5T  Female Tube O-Ring Swivel 90° Elbow Short Pilot	59PT  Male Tube O-Ring Swivel – Long Pilot Charge Port at 180° for R134a	5LPT  Female Tube O-Ring Swivel – 90° Elbow Long Pilot Charge Port at 180° for R134a	T1  Male Refrigerant Tube Mender – Straight (with Nut and Ferrule)

Hose Fittings Nomenclature

End Configuration	Description	Standards	Common Terms
01	Male NPTF Pipe – Rigid – Straight	SAE J476A / J516	AGN
02	Female NPTF Pipe – Rigid – Straight	SAE J476A / J516	
03	Male JIC 37° – Rigid – Straight	ISO12151-5-S	AGJ
04	Male SAE 45° – Rigid – Straight	SAE J516	
05	Male SAE Straight Thread with O-ring – Rigid – Straight	ISO 11926, SAE J516	
06	Female JIC 37° Swivel – Straight	ISO12151-5-SWS	DKJ
06/68	Female – JIC 37° / SAE 45° Dual Flare – Swivel – Straight	ISO12151-5-SWS	DKJ
07	Female NPSM Pipe Swivel		
08	Female SAE 45° – Swivel – Straight	SAE J516	
0C	Female Metric 24° – Heavy Series with O-ring – Swivel – 45° Elbow	ISO 12151-2 – SWE 45°-S	DKOS 45°
0G	Male O-ring Straight		
0L	Male O-ring 90° Elbow		
11	„Ferrul-Fix“		
12	Female Sae Flareless Swivel – Straight (24° Cone)		
13	Male NPTF Pipe Swivel	SAE J476A / J516	
15	SAE Code 61 – Flange Head – Straight	ISO 12151-3-S-L	SFL / 3000 psi
15/4A	SAE Code 61 – Flange Head – Straight / SAE Flange Head 5000 psi	ISO 12151-3-S-L	SFL
16	SAE Code 61 – Flange Head – 22.5° Elbow	ISO 12151-3-E22ML	SFL 22.5° / 3000 psi
17	SAE Code 61 – Flange Head – 45° Elbow	ISO 12151-3 – E45 – L	SFL 45° / 3000 psi
17/4F	SAE Code 61 – Flange – 45° Elbow – 45° Elbow (5000 psi)	ISO 12151-3 – E45S – L	SFL 45°
18	SAE Code 61 Flange – 67.5° Elbow	DIN 20078 R	SFL 67.5°
19	SAE Code 61 – Flange Head – 90° Elbow	ISO 12151-3 – E– L	SFL 90° / 3000 psi
19/4N	SAE Code 61 – Flange Head – 90° Elbow (5000 psi)	ISO 12151-3-E-L	SFL 90°
1C	Female Metric 24° – Heavy Series with O-ring – Swivel – 90° Elbow	ISO 12151-2-SWE-S	DKOS 90°
1D	Metric Standpipe – Light Series – Rigid – Straight	ISO 8434-1	BEL
1L	Male NPTF Pipe Swivel – 90° Elbow		
26	SAE Code 61 Flange – 30° Elbow		SFL 30°
27	SAE Code 61 Flange – 60° Elbow		SFL 60°
28	SAE Male Inverted 45° Elbow		
33	Male JIC 37° – Rigid – 45° Elbow	ISO 12151-5	AGJ 45°
34	Inch Standpipe (Brass)		
37	Female JIC 37° – Swivel – 45° Elbow	ISO 12151-5-SWE 45°	DKJ 45°
37/3V	Female JIC 37° /SAE 45° – Dual Flare – Swivel Female 45° Elbow	ISO 12151-5-SWE 45°	DKJ 45°
39	Female JIC 37° – Swivel – 90° Elbow	ISO 12151-5-SWES	DKJ 90°
39/3W	Female JIC 37° / SAE 45° – Dual Flare – Swivel Female 90° Elbow	ISO 12151-5-SWES	DKJ 90°
3D	Metric Standpipe – Heavy Series – Rigid – Straight	ISO 8434-1	BES
3V	Female JIC 37°/SAE – 45° Swivel – 45° Elbow		DKJ 45°
3W	Female JIC 37°/SAE – 45° Swivel – 90° Elbow		DKJ 90°
3Y	Female JIC 37°/SAE – 45° Swivel – 90° Elbow (Long)		DKJ 90°
41	Female JIC 37° Swivel – 90° Elbow (Long)		DKJ 90°

End Configuration	Description	Standards	Common Terms
41/3Y	Female JIC 37° / 45° Swivel Female 90° Elbow (Long)	ISO 12151-5-SWEL	DKJ 90°L
45	Male Tube O-ring Swivel – Long Pilot		
49	Metric Banjo – Straight	DIN 7642	
4A	5000 psi SAE Code 61 Flange – Straight		
4F	5000 psi SAE Code 61 Flange – 45° Elbow		
4N	5000 psi SAE Code 61 Flange – 90° Elbow		
59	Female Tube O-ring Swivel – Long Pilot		
59PT	Male Tube O-ring Swivel – Long Pilot	With Charge Port at 180° for R134a	
5C	60° Cone Swivel Female		
5D	Metric Standpipe – Light Series – Rigid – 90° Elbow	ISO 8434-1	BEL 90°
5G	Male Tube O-ring Rigid Port (3 step) Straight		
5GPR	Female Tube O-ring Rigid Port (3 step) Straight	With Charge Port for R12	
5H	Female Tube O-ring Swivel – 45° Elbow – Short Pilot		
5K	Male Tube O-ring Swivel – 90° Elbow – Short Pilot		
5LPR	Female Tube O-ring Swivel – 90° Elbow – Long Pilot		
5LPT	Female Tube O-ring Swivel – 90° Elbow – Long Pilot	With Charge Port at 180° for R134a	
5MPR	Male Tube O-ring Swivel – 90° Elbow – Long Pilot	With Charge Port at 180° for R12	
5MPV	Male Tube O-ring Swivel – 90° Elbow – Long Pilot	With Charge Port at 270° for R134a	
5N	Female Tube O-ring Swivel – 45° Elbow – Long Pilot		
5P	Female Tube O-ring Swivel – 45° Elbow – Long Pilot		
5R	Male Tube O-ring Swivel – 45° Elbow – Short Pilot		
5S	Female Tube O-ring Swivel – Short Pilot		
5T	Female Tube O-ring Swivel – 90° Elbow – Short Pilot		
5V	Female Compressor – Swivel 45° Elbow		
5W	Female Compressor – Swivel 90° Elbow		
5Z	Female Compressor – Swivel 90° Elbow – Block Type		
67	SAE Male Inverted Flare Swivel – 45° Elbow		
68	Female JIC 37° / SAE 45° Swivel		DKJ
69	SAE Male Inverted Flare Swivel – 90° Elbow		
6A	SAE Code 62 – Flange – Straight	ISO 12151-3-S-S	SFS / 6000 psi
6B	SAE Code 62 Flange – 22.5° Elbow		SFS 22.5°
6C	60° Cone Swivel Female – 45° Elbow		
6E	SAE Code 62 Flange – 30° Elbow		SFS 30°
6F	SAE Flange 45° Elbow – Heavy Series	ISO 12151-3 – E45-S	SFS 45° / 6000 psi
6G	SAE Code 62 Flange – 60° Elbow		SFS 60°
6N	SAE Code 62 Flange Head – 90° Elbow	ISO 12151-3 – E-S	SFS 90° / 6000 psi
77	Female SAE 45° Swivel – 45° Elbow		
79	Female SAE 45° Swivel – 90° Elbow		
7C	60° Cone Swivel Female – 90° Elbow		
7D	Male Standpipe Metric S – Rigid – 90° Elbow		BES 90°
82	Push-Lok® Union		
89	SAE Code 61 Flange – 90° Elbow (Long) – Standard Series	DIN 20 078 R	

End Configuration	Description	Standards	Common Terms
91	Male BSP Taper Pipe – Rigid – Straight	BS5200	AGR-K
92	Female BSP Parallel Pipe – Swivel – Straight (60° Cone)	BS5200-A	DKR
93	Female JIC 37° – Swivel – 90° Elbow (Block Type)		
9B	Metric – Swivel Female 45° Elbow – Light Series		
9C	Light Series Metric Swivel Female 90° Elbow		
AF	Male BSP Parallel Pipe – Rigid – Straight (with O-ring Seal)		
B1	Female BSP Parallel Pipe – Swivel – 45° Elbow (60° Cone)	BS 5200-D	DKR 45°
B2	Female BSP Parallel Pipe – Swivel – 90° Elbow (60° Cone)	BS 5200-B	DKR 90°
B4	Female BSP Parallel Pipe – Swivel – 90° Elbow Block Type (60° Cone)	BS 5200-E	DKR 90°
B5	Female BSP Parallel Pipe – Swivel – Straight (Flat Seat)		
C0	Female Metric – Very Light Series LL – Swivel – Straight (Ball Nose)		DKM
C3	Female Metric – Light Series – Swivel – Straight (Ball Nose)		DKL
C4	Female Metric – Light Series – Swivel – 45° Elbow (Ball Nose)		DKL 45°
C5	Female Metric – Light Series – Swivel – 90° Elbow (Ball Nose)		DKL 90°
C6	Female Metric – Heavy Series – Swivel – Straight (Ball Nose)		DKS
C7	Female Metric Swivel – 45° Elbow "Heavy" Series	DIN 20 078	DKS 45°
C8	Female Metric Swivel – 90° Elbow "Heavy" Series	DIN 20 078	DKS 90°
C9	Female Metric 24° – Heavy Series with O-ring – Swivel – Straight	ISO 12151-2-SWS-S	DKOS
CA	Female Metric 24° – Light Series with O-ring – Swivel – Straight	ISO 12151-2-SWS-L	DKOL
CE	Female Metric 24° – Light Series with O-ring – Swivel – 45° Elbow	ISO 12151-2-SWE 45°-L	DKOL 45°
CF	Female Metric 24° – Light Series with O-ring – Swivel – 90° Elbow	ISO 12151-2-SWE-L	DKOL 90°
CW	Power Cleaner Connection		
D0	Male Metric 24° – Light Series – Rigid – Straight	ISO 12151-2-S-L	CEL
D2	Male Metric 24° – Heavy Series – Rigid – Straight	ISO 12151-2-S-S	CES
D9	Male BSP Parallel Pipe – Rigid – Straight (60° Cone)	BS5200	AGR
DD	Metric Standpipe – Light Series – Rigid – 45° Elbow		BEL 45°
DE	Double Banjo Union		
DK	Male Metric L – Rigid – Bulkhead with Locknut (24° Cone)		
DP	Metric Swivel Female Tee / Male Stud		
DR	Metric Swivel Female Tee		
DS	Metric Swivel Female Tee / Standpipe		
DW	Female Metric Swivel „Light“ Series		TGL
DX	Female Metric Swivel (M27x2) O-ring – Light Series		
EA	BSP Swivel Female with O-ring (60° Cone)	BS 5200, ISO 12151-6	DKOR
EB	BSP Swivel Female with O-ring – 45° Elbow (60° Cone)	BS 5200, ISO 12151-6	DKOR 45°
EC	BSP Swivel Female with O-ring – 90° Elbow (60° Cone)	BS 5200, ISO 12151-6	DKOR 90°
F2	Female French Swivel Female – Gas Series 90° Elbow		
F4	Female French Gas Series – Swivel – Straight (Ball Nose)		

End Configuration	Description	Standards	Common Terms
F6	French Male Metric Series (24° Cone)		
F9	French Swivel Female Metric Series – (Ball Nose)		
FA	Metric Male For Agriculture Valves		
FB	French Metric		
FF	Metru-Lok Swivel Female		
FG	Male French Gas Series – Rigid – Straight (24° Cone)		
FU	Female BSP Parallel Pipe – Swivel – Straight (30° Flare)	ISO 228-1, JIS B8363	GUI
GE	French Gas Standpipe		
GU	Female BSP Parallel Pipe – Swivel – Straight (60° Cone)	ISO 228-1, JIS B8363	GUO
J1	Female ORFS – Swivel – 90° Elbow – Long Drop	ISO 12151-1 – SWEL, SAE J 516	ORFS 90° L
J5	Female ORFS – Swivel – 90° Elbow – Medium Drop	ISO 12151-1 – SWEM	ORFS 90° M
J7	Female ORFS – Swivel – 45° Elbow	ISO 12151-1 – SWE 45°, SAE J516	ORFS 45°
J9	Female ORFS – Swivel – 90° Elbow – Short Drop	ISO 12151-1 – SWES, SAE J516	ORFS 90°
JC	Female ORFS – Swivel – Straight – Short	ISO 12151-1 – SWSA, SAE J516	ORFS
JD	Male ORFS – Bulkhead with Locknut – Straight (with O-ring)	ISO 12151-1 – SAE J516	
JM	ORFS Male	ISO 12151-1-S, SAE J516	
JS	ORFS Swivel Female (Long)	ISO 12151-1-SWSB, SAE J516	ORFS
L9	Female JIC 37° – Swivel – 90° Elbow – Medium Drop	ISO 12151-5-SWEM	DKJ 90° M
MU	Female Metric – Swivel – Straight (30° Flare)	JIS B8363	MU
MZ	Female Metric – Swivel – 90° Elbow (30° Flare)	JIS B8363	
NM	Male BSP Parallel Pipe – L Series – Rigid – Straight – ED-Seal	ISO 1179	
NW	Female Kärcher Metric Cleaning Hose Fitting – Swivel – Straight	(New Design)	
PW	Male Kärcher Metric Cleaning Hose Fitting – Rigid – Straight		
S2	Female NPTF Pipe Swivel		
S5	Male Tube O-ring Swivel – Short Pilot		
T1	Male Refrigerant Tube Mender – Straight (with Nut and Ferrule)		
UT	Male BSP Taper Pipe – Rigid – Straight (60° Cone)	JIS B 8363-R	
V1	Ermeto standard Pressuree Banjo – Straight (with UNF Bolt and O-ring)		
VW	Push In Connector	(VW-Standard 39-V-16619)	
VW121	BSP Swivel Female	(VW-Norm 39-V-16631)	
VW39D	Push In Connector	(VW-Standard 39D-1401)	
WKS	Rubber hand grip		
XA	Caterpillar® Flange Head – Straight		
XF	Caterpillar® Flange Head – 45° Elbow		
XG	Caterpillar® Flange Head – 60° Elbow		
XN	Caterpillar® Flange Head – 90° Elbow		
XU	Female Metric – Swivel – Straight (30° Flare)	JIS B8363	
XY	Female Metric – Swivel – 90° Elbow (30° Flare)	JIS B8363	
YW	Male Standpipe – Rigid – Straight – A-Lok	Metric Size Tube O.D. with Vee Notch	

Classification Body Type Approvals

Description (1)-(14) see Ab-11

	Hose	Reinforcement	Norm EN/ISO	GL (1)	DNV (2)	RINA (3)	DB/DIN 5510 (4)	LR (5)	MOD (6)	ABS (7)	DOT (8)	USCG (9)	MSHA (10)	BV (11)	NF (12)	BS 6853 (13)	MarED (14)
Low Pressure Push-Lok Hoses	801	1 braid, fibre															
	804	1 braid, fibre															
	821FR	1 braid, fibre															
	830M	1 braid, fibre															
	831	1 braid, fibre															
	836	1 braid, fibre											X				
	837BM	1 braid, fibre															
	837PU	1 braid, fibre															
	838M	1 braid, fibre															
Low Pressure Speciality Hoses	201	1 braid, wire	SAE 100 R5 / SAE J1402 All								X						
	206	1 braid, wire	SAE 100 R5 / SAE J1402 All				X				X						
	213	1 braid, wire	SAE J1402 All								X						
	221FR	1 braid, wire	SAE J1527 Typ R3	X	X					X		X	X				
	285	1 braid, wire	SAE J2084 Typ C														
	293	1 braid, fibre	SAE J1402 All								X						
	601	2 braids, fibre	SAE 100 R3									H	X				
	611HT	1 braid, fibre	EN 854-R6														
	681DB	2 braids, fibre	EN 854-2TE				X								X	X	
Medium Pressure	301SN	2 braids, wire	EN 853-2SN	X	X	X		X		X				X			X
	302	2 braids, wire	EN 853-2SN / ISO 1436		X					X		X					
	304	2 braids, wire	SAE 100 R2 AT														
	402	1 braid, wire															
	421RH	1 braid, wire	EN 853-1SN				X								X	X	
	421SN	1 braid, wire	EN 853-1SN	X	X	X		X		X				X			X
	421WC	1 braid, wire	SAE 100 R1 AT														
	422	1 braid, wire	EN 853-1SN / ISO1436		X					X		X					
	424	1 braid, wire	SAE 100 R1 AT														
	426	1 braid, wire	SAE 100 R1 AT							X		X	X				
	436	2 braids, wire	SAE 100 R16		X		X			X		H	X				
	441	1 braid, wire	SAE 100 R16									H					
	441RH	1 braid, wire	SAE 100 R16				X								X	X	
	451TC	1 braid, wire	SAE 100 R17							X		H	X				
	461LT	2 braids, wire	EN 857-2SC														
	462	2 braids, wire	EN 857-2SC	X	X	X	X	X						X			
	462ST	2 braids, wire	EN 857-2SC														
	463	2 braids, wire															
	471TC	2 braids, wire	EN 857-2SC		X					X		H	X				
	472TC	1 braid, wire	EN 857-2SC		X					X							
	492	1 braid, wire	EN 857-1SC	X	X	X	X	X							X		
	492ST	1 braid, wire	EN 857-1SC														
	493	1 braid, wire															
	692	1/2 braids, wire	SAE 100 R17														
692Twin	1/2 braids, wire	SAE 100 R17															
811	1 braid, 1 steel spiral	SAE 100 R4										H	X				
881	1 braid, 1 steel spiral	SAE 100 R4										H	X				
High Pressure	371LT	3 braids, wire															
	372	3 braids, wire		X	X		X	X						X			X
	372RH	3 braids, wire					X								X	X	
	372TC	3 braids, wire											X				
	701	4 spiral, wire	EN 856-4SP			X						H					
	721TC	4 spiral, wire	SAE 100 R12									H	X				
	731	4 spiral, wire	EN 856-4SH									H					
	774	4 spiral, wire															
	781	4/6 spiral, wire	SAE 100 R13														
	P35	6 spiral, wire	SAE 100 R13							X		H					
	791TC	4/6 spiral, wire	SAE 100 R15		X					X		H	X				
792TC	4/6 spiral, wire	SAE 100 R15		X					X		H	X					

Classification Bodies

The mission of classification bodies is to contribute to the development and implementation of technical standards for the protection of life, property and the environment.

(1) Germanischer Lloyd (GL)

German independent organisation of technical experts approving products for the German merchandise marine and the energy sector - GLIS (oil and gas, wind energy, etc...)

(2) Det Norske Veritas (DNV)

Norwegian service company for managing risk in ship classification, off-shore industry, etc...

(3) RINA (Registro Italiano Navale)

Italian company offering certification, verification, control, assistance in marine, energy & process, transport and industry.

(4) Deutsche Bahn (DB) - German Standard DIN 5510 - Part 2

The German rail authority (DB) approves the behaviour of the products in respect to their resistance to burning and their ability to self extinguish after a flaming, according to the DIN 5510-2 requirements.

(5) Lloyd's Register (LR)

English independent organisation providing certification around the world. Marine services, Rail services and Energy services are their main activities.

(6) Ministry of Defence (MOD)

British ministry of defence providing approvals for military equipment according to the MOD DefStan (Defence Standard) 47-2 specification.

(7) American Bureau of Shipping (ABS)

US company providing rules for safety in the marine environment.

(8) US Department of Transportation (DOT)

USA organisation providing certifications to ensure a fast, safe, efficient, accessible and convenient transportation system in this country.

(9) US Coast Guard (USCG)

Provides maritime safety, law enforcement, recreational boating safety, and environmental protection information for merchant mariners. The approved hoses are not accepted for all applications automatically. If the column contains "H", the hose is accepted for Hydraulic Systems only and not for Fuel and lube systems.

(10) Mine Safety and Health Administration (MSHA)

US organisation for safety in the mining industry

(11) Bureau Veritas (BV)

Bureau Veritas is today the most widely recognized certification body in the world, offering solutions in the key strategic fields of operations: Quality, Health & Safety, Environment and Social Responsibility.

(12) French Standard NF F-16-101/102 (NF)

Tests the fire behaviour and fire effluents of the hose cover material for rail applications.

(13) British Standard (BS 6853)

Tests the fire behaviour and fire effluents of the hose cover material for rail applications.

(14) MarED

MarED is the Group of Notified Bodies for the Implementation of the Marine Equipment Directive.

EN	European Norm
ISO	International Organisation for Standardization
SAE	Society of Automotive Engineers (US organisation)

Conversion Chart

	Unit	Base Unit	Conversion Unit	Factor
Length	1 inch	in	mm	25,4
	1 millimetre	mm	in	0,03934
	1 foot	ft	m	0,3048
	1 metre	m	ft	3,28084
Area	1 square-inch	sq in	cm ²	6,4516
	1 square-centimetre	cm ²	sq in	0,1550
Volume	1 gallon (UK)	gal	l	4,54596
	1 litre	l	gal (UK)	0,219976
	1 gallon (US)	gal	l	3,78533
	1 litre	l	gal (US)	0,264177
Weight	1 pound	lb	kg	0,453592
	1 kilogramme	kg	lb	2,204622
Torque	1 pound foot	lb • ft	kg • m	1,488164
	1 newton metre	kg • m	lb • ft	0,671969
Pressure	1 pound per square inch	psi	bar	0,06895
	1 bar	bar	psi	14,5035
	1 pound per square inch	psi	MPa	0,006895
	1 mega pascal	MPa	psi	145,035
	1 kilo pascal	kPa	bar	0,01
	1 bar	bar	kPa	100
	1 mega pascal	MPa	bar	10
	1 bar	bar	MPa	0,1
Velocity	1 foot per second	ft / s	m / s	0,3048
	1 metre per second	m / s	ft / s	3,28084
Flow rate	1 gallon per minute (UK)	gal / min.	l / min.	4,54596
	1 litre per minute	l / min.	gal / min. (UK)	0,219976
	1 gallon per minute (US)	gal / min.	l / min.	3,78533
	1 litre per minute	l / min.	gal / min. (US)	0,264178
Temperature	Fahrenheit degree	°F	°C	5/9 • (°F-32)
	Celsius degree	°C	°F	°C • (9 / 5) +32

(UK) Unit of United Kingdom
 (US) Unit of USA

Temperature / Pressure Chart

Reference 201, 206, 213 and 293 hose.

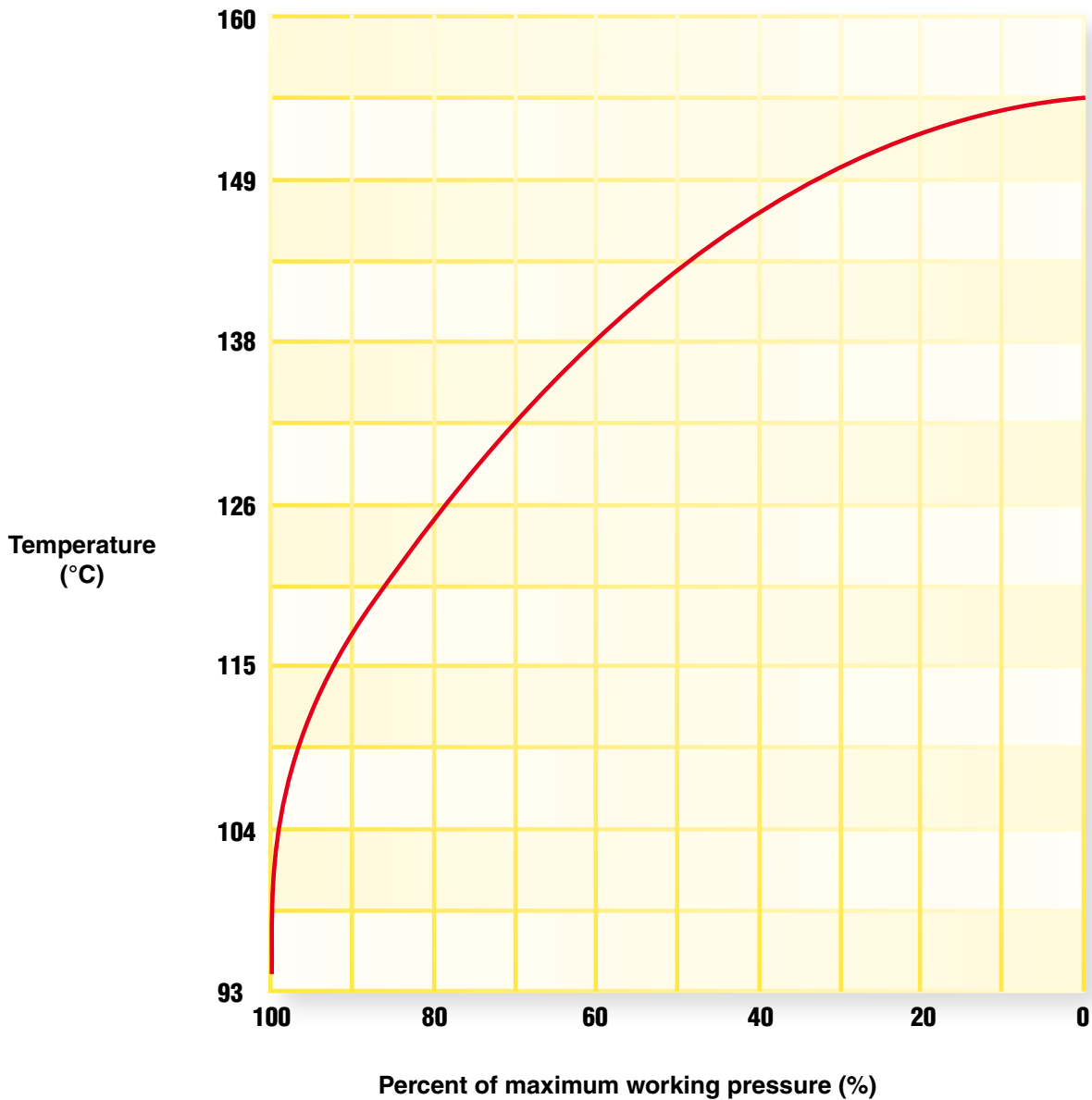

EXAMPLE: 201-8 hose to be used at 121 °C

Maximum Working Pressure up to 100 °C	x	Multiplication Factor from Chart	=	Maximum Working Pressure at 121 °C
13,8 MPa (2000 psi)	x	85%	=	11,7 MPa (1700 psi)

Flow Capacity Nomogram

Flow Capacities of Parker Hose at Recommended Flow Velocities

The chart below is provided as an aid in the determination of the correct hose size.

Example: at 10 gallons per minute (gal/min), what is the proper hose size within the recommended velocity range for pressure lines?

Locate 10 gallons per minute in the left-hand column and 20 feet per second in the right-hand column (the maximum recommended velocity range for pressure lines). Lay a straight line across these two points. The inside diameter shown in the centre column is above -6 so we have to use -8 (1/2").

For suction hose, follow the same procedure except use recommended velocity range for intake lines in the right-hand column.

where: Q = flow in gallons per minute (gal/min & l/min)
 V = velocity in feet per second (f/s & m/s)
 d = hose inside diameter (mm & dash size)

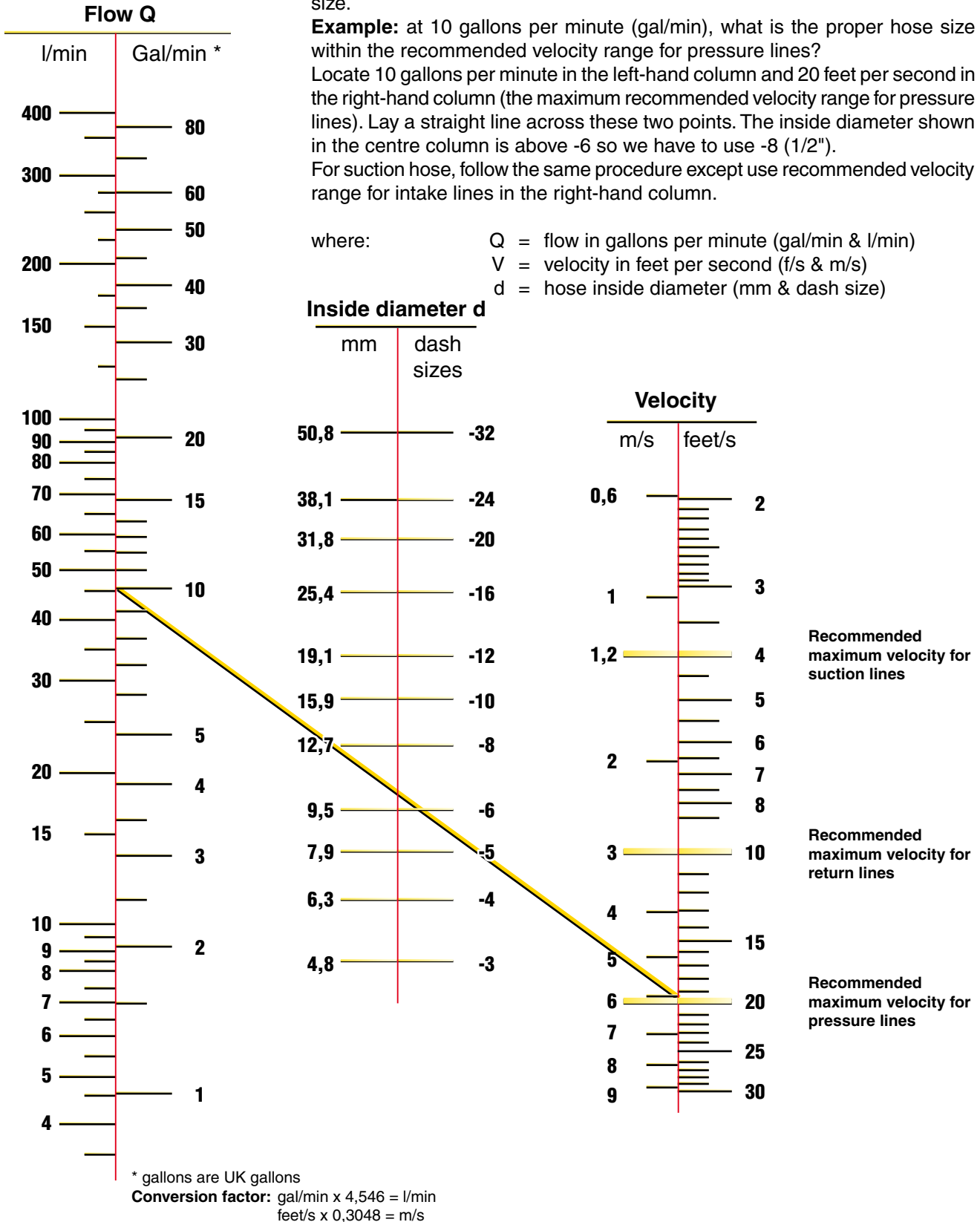

* Recommended velocities are according to hydraulic fluids of maximum viscosity 315 S.S.U. at 38°C working at roomtemperature within 18° and 68°C.

The Correct Method to Fit Female Swivel Ends

To ensure a leakproof seal between swivel female hose ends shown in this catalogue and the appropriate adaptors it is necessary to follow the procedure below which is different from hydraulic tube assembly.

Flats From Wrench Resistance (FFWR)

Parker's recommended assembly method for JIC 37° flare, SAE 45° flare and ORFS swivel female is Flats From Wrench Resistance (FFWR). The torque values assigned by size are for reference only, and are only applicable to Parker system components using the FFWR method with trivalent chromate passivation on zinc plating of carbon steel components without lubrication.

Metal-to-metal seal

Screw the nut up hand tight and then tighten further with a spanner according to the values mentioned in the table below. Ensure that in all cases the hose is correctly aligned before tightening the nut onto the corresponding adaptor.

Spanner torque values

Metric swivel female

Thread metric	Tube O.D.	Nm	
		nominal	min. - max.
M 12x1,5	06L	16	15 - 17
M 14x1,5	08L	16	15 - 17
M 16x1,5	10L	26	25 - 28
M 18x1,5	12L	37	35 - 39
M 22x1,5	15L	47	45 - 50
M 26x1,5	18L	89	85 - 94
M 30x2	22L	116	110 - 121
M 36x2	28L	137	130 - 143
M 45x2	35L	226	215 - 237
M 52x2	42L	347	330 - 363
M 14x1,5	06S	26	25 - 28
M 16x1,5	08S	42	40 - 44
M 18x1,5	10S	53	50 - 55
M 20x1,5	12S	63	60 - 66
M 22x1,5	14S	79	75 - 83
M 24x1,5	16S	84	80 - 88
M 30x2	20S	126	120 - 132
M 36x2	25S	179	170 - 187
M 42x2	30S	263	250 - 275
M 52x2	38S	368	350 - 385

BSP swivel female

Thread BSPP	size	Nm	
		nominal	min. - max.
G1/4	-4	20	15 - 25
G3/8	-6	34	27 - 41
G1/2	-8	60	42 - 76
G5/8	-10	69	44 - 94
G3/4	-12	115	95 - 135
G1	-16	140	115 - 165
G1.1/4	-20	210	140 - 280
G1.1/2	-24	290	215 - 365
G2	-32	400	300 - 500

Note

Values given in tables are typical to achieve the recommended assembly methods when fitting material is steel zinc plated. For other materials different values will be applicable. (see our recommendations for other materials on this page)

JIC 37° swivel female

Thread UNF	size	Flats From Wrench Resistance (FFWR)	Swivel Nut Torque Nm (Ref)
7/16-20	-4	2	18
1/2-20	-5	2	23
9/16-18	-6	1-1/2	30
3/4-16	-8	1-1/2	57
7/8-14	-10	1-1/2	81
1.1/16-12	-12	1-1/4	114
1.5/16-12	-16	1	160
1.5/8-12	-20	1	228
1.7/8-12	-24	1	265
2.1/2-12	-32	1	360

ORFS swivel female

Thread UNF	size	Flats From Wrench Resistance (FFWR)	Swivel Nut Torque Nm (Ref)
9/16-18	-4	1/2 to 3/4	26
11/16-16	-6	1/2 to 3/4	42
13/16-16	-8	1/2 to 3/4	57
1-14	-10	1/2 to 3/4	85
1.3/16-12	-12	1/3 to 1/2	122
1.7/16-12	-16	1/3 to 1/2	156
1.11/16-12	-20	1/3 to 1/2	200
2-12	-24	1/3 to 1/2	256
2-1/2x12	-32	-	-

Note: The assembly torques listed are higher than the test torques published in SAE J1453.

The torque values for other materials are as follows:

- Brass fittings and adapters
 - 65 % of the torque value for steel.
- Stainless steel and Monel
 - Use 5% higher than listed for steel.
 - Threads to be lubricated for these materials.
- Dissimilar metals
 - Use torque value designated for the lower of the two metals.
- All fittings are dry except as noted above.

Chemical Resistance Table

Warning ! This chemical compatibility guide must not be used in conjunction with any other compatibility guides from previous or future catalogue editions, bulletins or publications. Incorrect use of these charts could result in death, personal injury or property damage.

Hose Selection by Medium and Hose Type

This hose compatibility chart is a ready reference of Parker hose compatibility with various fluid media. It is intended as a guide to **chemical compatibility** with **inner tube materials and assembly lubricants applied internally**.

The outer cover of the hose is intended to protect the reinforcement layer(s) from mechanical influences (abrasion, weathering etc), as such the **cover compounds are not designed to exhibit the same chemical resistance as the tube compounds**. Hose Division Technical Department should be consulted about the compatibility of the cover should the application involve the extended exposure or immersion in a liquid.

The specific recommendations are based upon field experience, the advice of various polymer or fluid suppliers, and specific laboratory experiments. It must be stressed, however, that this information is offered only as a guide. Final hose selection depends also upon pressure, fluid temperature, ambient temperature, and special requirements or variations, which may not be known by Parker Hannifin. Legal and other regulations must be followed with particular care.

Where an external compatibility problem may occur, or for fluids not listed, we encourage you to first contact the fluid manufacturer for a recommendation prior to contacting your Parker Hannifin Field Representative or the Technical Department, Hose Products Division Europe (HPDE@Parker.com)

Use the Chart as Follows:

1. Locate medium to be carried using the Chemical Resistance Table on the following pages.
2. Select suitability of hose and fitting material from the table based on the letter rating in the table. See resistance rating key below for explanation of compatibility ratings. See list of numerals below for an explanation when a numeral, or a numeral and a letter rating are present in the table.
3. The Column headings on the Chemical Resistance Table, I, II, III, IV, V, refer to specific groups of hoses.
4. Locate hose part number under Column I, II, III, IV, V, VI from the list below.
5. For fitting material availability refer to appropriate fitting section of catalogue.
6. Check hose specifications in this catalogue. Contact Hose Division Technical Department on any items not catalogued.

Resistance Rating Key

- A = Preferred, good to excellent with little or no change in physical properties.
- F = Fair, marginal or conditional with noticeable effects on physical properties.
- X = Unsuitable, severe effects on physical properties.
- ~ = No rating, insufficient information.

Numerals

1. For air or gaseous applications above 250 PSI (1,7 MPa), the cover should be pin pricked.
2. Legal and insurance regulations must be considered. Contact HPDE Technical Department for more information.
3. Push-Lok hoses (801, 804, 821, 821FR, 831, 836, 837BM, 837PU, 830M, 838M) are not recommended for any type of fuel.
4. Use 285, 235 or 244 hoses. The compatibility of the systems refrigeration oil with these hoses needs to be evaluated on a case by case basis. Contact HPDE Technical Department for more information. Do not use mineral oil or Alkyl Benzene refrigeration oils with 244 hose. Chemical compatibility does not imply low permeation.
5. 65 °C (150 °F) maximum.
6. Satisfactory at some concentrations and temperatures, unsatisfactory at others.
7. For phosphate ester fluids use 304, 424, 774 or 804 hoses.
8. Acceptable for flushing hose assemblies.
9. 221FR hose recommended.
10. For dry air applications, hoses with inner tubes from columns IV, and V are preferred. See hose specifications for maximum recommended temperatures with air.
11. 100 °C (212 °F) maximum.
12. 121 °C (250 °F) maximum.
13. Hoses for gas application are available from Parker. Please contact the Technical Department for more information about the products as well as the legal application requirements.
14. Hoses for gas application are available from Parker. Please contact the Technical Department for more information about the products as well as the legal application requirements.
15. 70 °C maximum for hoses 801, 837BM, 837PU
16. No rating / insufficient information about chemical compatibility for hoses 801, 837BM, 837PU.

Hose Types

Column I: 201, 225, 601, 701, 721, 721TC, 731, 77C, P35, 781, 791TC, 881

Column IV: 206, 213, 226, 266, 293, 426, 436, 611HT, 821FR, 836, 801*, 837BM*, 837PU*

Column II: 371LT, SS25UL, 421WC, 431, 441, 441RH, 451TC, 451ST, 461LT, 463, 471TC, 471ST, 493, 681DB, 811

Column V: 304, 424, 604, 774, 804

Column III: 221FR, 301SN, 302, 372, 372RH, 372TC, 402, 421RH, 421SN, 422, 462, 462ST, 472TC, 492, 492ST, 692, 692Twin, 772TC, 772ST, 782TC, 782ST, 792TC, 792ST, 821, 831

Column VI: 830M, 838M

Note: * See Numeral 15,16

Caution: The fluid manufacturer's recommended maximum operating temperature for any specific name-brand fluid should be closely observed by the user. Specific name brand fluids can vary greatly between manufacturers even though they are considered to be from the same family or-of fluids. Using fluids above the manufacturers maximum recommended temperature can cause the fluid to break down, creating by-products that can be harmful to elastomers or other materials used in the system. When selecting a hose type, both the fluid manufacturer and hose manufacturers maximum temperature limit must be taken into consideration, with the lower of the taking precedence.

Medium	I	II	III	IV	V	VI	STEEL	BRASS	SS
3M FC-75	A	A	A	A 16	A	A	A	A	A
Acetic Acid	X	X	X	A 16	6	X	X	X	A
Acetone	X	X	X	A 16	A	X	A	A	A
Acetylene	X	X	X	X	X	-	-	-	-
AEROSHELL Turbine Oil 500 (See MIL-L-23699)	X	X	F	X	X	-	A	A	A
Air	A, 1, 10	A, 1, 10	A, 1, 10	A 1, 10	A, 1, 10	A	A	A	A
Air (dry)	X	F, 1, 10	F, 1, 10	A 1, 10	A, 1, 10	A	A	A	A
Alcohol (Methanol-Ethanol)	F	F	F	A 16	F	-	F	A	A
Ammonia (Anhydrous)	X	X	X	X	X	-	X	X	X
Ammonium Chloride	A	A	A	A 16	A	A	X	X	X
Ammonium Hydroxide	F	F	F	A 16	A	X	F	X	A
Ammonium Nitrate	A	A	A	A 16	A	-	F	X	A
Ammonium Phosphate	A	A	A	A 16	A	-	X	X	F
Ammonium Sulfate	A	A	A	A 16	A	-	F	X	F
Amoco 32 Rykon	X	A	A	F 15	X	A	A	A	A
Ampol PE 46	X	X	X	X	A, 7	F	A	A	A
AMSOIL Synthetic ATF	F	A	A	A 16	X	F	A	A	A
Amyl Alcohol	X	X	X	A 16	F	-	X	A	A
Anderol 495,497,500,750	X	X	X	A 16	X	X	A	A	A
Aniline	X	X	X	A 16	A	X	A	X	A
Animal Fats	X	F	F	A 16	F	-	6	6	A
Aquacent Light, Heavy	X	A	A	X	X	A	A	A	A
Argon	A	A	A	A	A	A	A	A	A
Aromatic 100,150	X	F	F	-	X	F	A	A	A
Arrow 602P	A	A	A	A 15	X	A	A	A	A
Asphalt	X	F	F	F 15	X	A	F	F	A
ASTM #3 Oil	F	F	F	A 16	X	-	A	A	A
ATF-M	F	A	A	A 15	X	A	A	A	A
Automotive Brake Fluid	X	X	X	X	-	X	X	X	X
AW 32,46,68	F	A	A	A 15	X	A	A	A	A
BCF	F	F	F	F 16	-	-	A	A	A
Benz Petraulic 32,46,68,100,150,220,320,460	F	A	A	A 15	X	A	A	A	A
Benzene, Benzol	X	X	X	A 16	X	F	A	A	A
Benzgrind HP 15	-	A	A	A 16	X	-	A	A	A
Benzine	X	X	X	F 16	X	-	A	A	A
Biodegradable Hydraulic Fluid 112B	X	A	A	X	-	-	A	A	A
Borax	F	F	F	A 16	A	-	F	A	A
Boric Acid	A	A	A	X	A	X	X	6	A
Brayco 882	X	A	A	A 16	X	-	A	A	A
Brayco Micronic 745	X	X	A	F 15	X	A	A	A	A
Brayco Micronic 776RP	F	A	A	F 15	X	A	A	A	A
Brayco Micronic 889	X	F	F	-	X	-	A	A	A
Brine	F	F	F	A 16	A	-	X	F	F
Butane		See 2 & 13				F	A	A	A
Butyl Alcohol, Butanol	F	F	F	A 16	F	-	F	F	A
Calcium Chloride	A	A	A	A 16	A	-	F	F	X
Calcium Hydroxide	A	A	A	A 16	A	-	A	A	A
Calcium Hypochlorite	X	X	X	A 16	A	-	X	F	X
Calibrating Fluid	A	A	A	A 15	X	A	A	A	A
Carbon Dioxide, gas	F	F	F	F 16	6	-	A	A	A
Carbon Disulfide	X	X	X	A 16	X	-	A	F	A
Carbon Monoxide (hot)	F	F	F	A 16	6	-	F	6	A
Carbon Tetrachloride	X	X	X	A 16	X	-	6	6	6
Carbonic Acid	F	F	F	X	F	X	X	X	F
Castor Oil	A	A	A	A 16	A	-	A	A	A
Castrol 5000	X	F	F	A 16	X	X	A	A	A
Cellosolve Acetate	X	X	X	X	A	-	X	X	A
Cellugard	A	A	A	-	A	-	A	A	A
Cellulube 90, 150, 220 300, 550, 1000	X	X	X	-	A	-	A	A	A
Chevron Clarity AW 32, 46, 68	A	A	A	A 15	X	A	A	A	A
Chevron FLO-COOL 180	F	F	F	-	X	-	A	A	A
Chevron FR-8, 10, 13, 20	X	X	X	X	A, 7	F	A	A	A
Chevron Hydraulic Oils AW MV 15, 32, 46, 68, 100	A	A	A	A 15	X	A	A	A	A
Chevron HyJet IV (9)	X	X	X	X	A, 7	F	A	A	A
Citric Acid	F	A	A	X	A	X	X	X	6
Commonwealth EDM 242, 244	A	A	A	-	X	A	A	A	A
CompAir CN300	X	X	X	A 16	X	X	A	A	A
CompAir CS100, 200, 300, 400	X	X	X	A 16	X	X	A	A	A
Coolanol 15, 20, 25, 35, 45	A	A	A	A 16	A	X	A	A	A
Copper Chloride	F	A	A	X	A	-	X	X	X
Copper Sulfate	A	A	A	X	A	-	X	X	F
Cosmolubric HF-122, HF-130, HF-144	X	F	A	X	X	-	A	A	A
Cosmolubric HF-1530	X	F	A	X	X	-	A	A	A
Cottonseed Oil	F	A	A	F 16	X	-	A	A	A
CPI CP-4000	X	X	X	A 16	X	-	A	A	A
Crude Petroleum Oil	F	A	A	A 15	X	A	F	F	A

Medium	I	II	III	IV	V	VI	STEEL	BRASS	SS
CSS 1001 Dairy Hydraulic Fluid	F	A	A	A 16	X	-	A	A	A
Daphne AW32	A	A	A	A 15	X	A	A	A	A
Dasco FR 201-A	A	A	A	-	X	-	A	A	A
Dasco FR150, 200, 310	F	A	A	-	A	-	A	A	A
Dasco FR300, FR2550	X	X	X	-	X	F	A	A	A
Dasco FR355-3	X	F	A	X	X	X	A	A	A
Deicer Fluid 419R	A	A	A	-	-	A	A	A	A
Deionized Water	A	A	A	A 16	A	-	F	F	A
Dexron II ATF	F	A	A	A 15	X	A	A	A	A
Dexron III ATF	X	F, 11	F, 11	A 16, 12	X	-	A	A	A
Diesel Fuel	F, 3	A, 3	A, 3	A 16, 3	X	A(2)	A	A	A
Diester Fluids	X	X	X	A 16	X	X	A	A	A
Dow Corning 2-1802 Sullair (24KT)	-	-	-	F 16	-	-	A	A	A
Dow Corning DC 200, 510, 550, 560, FC126	A	A	A	A 16	-	-	A	A	A
Dow HD50-4	F	F	F	-	-	-	-	-	A
Dow Sullube 32	-	-	-	F 16	-	-	A	A	A
Dowtherm A,E	X	X	X	A 16	X	-	A	A	A
Dowtherm G	X	X	X	X	X	-	A	A	A
Duro AW-16, 31	A	A	A	-	X	-	A	A	A
Duro FR-HD	A	A	A	-	X	-	A	A	A
EcoSafe FR-68	A	A	A	-	X	X	A	A	A
Ethanol	F	F	F	A 16	F	-	F	A	A
Ethers	X	X	X	A 16	X	-	A	A	A
Ethyl Acetate	X	X	X	A 16	F	-	F	A	A
Ethyl Alcohol	F	F	F	A 16	F	-	F	A	A
Ethyl Cellulose	F	F	F	A 16	F	-	X	F	F
Ethyl Chloride	X	X	X	X	A	-	F	F	F
Ethylene Dichloride	X	X	X	A 16	X	-	X	A	X
Ethylene Glycol	F	A	A	A	A	A	A	F	A
Exxon 3110 FR	A	A	A	A 16	X	A	A	A	A
Exxon Esstic	A	A	A	A 15	A	A	A	A	A
Exxon Nuto H 46, 68	A	A	A	A 15	X	A	A	A	A
Exxon Tellura Industrial Process Oils	A	A	A	A 15	X	A	A	A	A
Exxon Terresstic, EP	A	A	A	A 15	A	A	A	A	A
Exxon Turbo Oil 2380	X	F	F	A 16	X	X	A	A	A
Exxon Univolt 60, N61	F	A	A	A 15	X	A	A	A	A
FE 232 (Halon)	X	X	X	X	F	-	A	A	A
Fenso 150	-	A	A	-	X	A	A	A	A
Formaldehyde	X	X	X	A 16	A	-	X	F	A
Formic Acid	X	X	X	X	A	X	X	6	X
Freons see refrigerants	-	-	-	-	-	-	-	-	-
Fuel Oil	F	A	A	A 15	X	A	A	A	A
Fyre-Safe 120C, 126, 155, 1090E, 1150, 1220, 1300E	X	X	X	X	A, 7	F	A	A	A
Fyre-Safe 200C, 225, 211	F	A	A	A	A	F	A	A	A
Fyre-Safe W/O	A	A	A	A 16	X	A	A	A	A
Fyrguard 150, 150-M, 200	A	A	A	A	A	F	A	A	A
Fyrquel 60, 90, 150, 220, 300, 550, 1000	X	X	X	X	A, 7	F	A	A	A
Fyrquel EHC, GT, LT, VPF	X	X	X	X	A, 7	F	A	A	A
Fyrtek MF, 215, 290, 295	X	X	X	X	X	F	A	A	A
Gardner-Denver GD5000, GD8000	X	X	X	A 16	X	X	A	A	A
Gasoline	-	See 9	-	-	-	-	A	A	A
Glue	F	F	F	-	X	-	A	F	A
Glycerine, Glycerol	A	A	A	A 16	A	-	A	F	A
Grease	A	A	A	A 15	X	A	A	A	A
Gulf-FR Fluid P37, P40, P43, P45, P47	X	X	X	A 16	A	-	A	A	A
H-515 (NATO)	A	A	A	-	X	-	A	A	A
Halon 1211, 1301	F	F	F	F 16	-	-	A	A	A
Helium Gas	X	X	X	X	X	-	A	A	A
Heptane	X	F	F	A 16	X	-	A	A	A
Hexane	X	F	F	A 16	X	-	A	A	A
HF-20, HF-28	-	A	A	A	A	F	A	A	A
Houghto-Safe 1055, 1110, 1115, 1120, 1130 (9)	X	X	X	X	A, 7	F	A	A	A
Houghto-Safe 271 to 640	F	A	A	A	A	F	A	A	A
Houghto-Safe 419 Hydraulic Fluid	A	A	A	-	X	-	A	A	A
Houghto-Safe 419R Deicer Fluid	A	A	A	-	-	A	A	A	A
Houghto-Safe 5046, 5046W, 5047-F	A	A	A	A 16	X	-	A	A	A
HP 100C (Jack hammer oil)	F	A	A	A 15	X	A	A	A	A
HPWG 46B	F	A	A	A	-	F	A	A	A
Hul-E-Mul	A	A	A	-	X	-	A	A	A
Hychem C, EP1000, RDF	A	A	A	A 16	A	-	A	A	A
Hydra Safe E-190	A	A	A	A 16	X	-	A	A	A
Hydra-Cut 481, 496	A	A	A	-	X	-	A	A	A
Hydrafluid 760	A	A	A	-	X	-	A	A	A
Hydrochloric Acid	X	X	X	X	X	X	X	X	X
Hydrofluoric Acid	X	X	X	X	X	X	X	6	X
Hydrogen Gas	X	X	X	X	X	-	A	A	A

Medium	I	II	III	IV	V	VI	STEEL	BRASS	SS
Hydrogen Peroxide	X	X	X	A 16	X	-	X	X	6
Hydrogen Sulfide	X	X	X	X	A	-	X	X	6
Hydrolube	A	A	A	A 16	A	-	A	A	A
Hydrolubric 120-B, 141, 595	F	A	A	A 16	A	-	A	A	A
Hydrosafe Glycol 200	A	A	A	A	A	F	A	F	A
HyJet IV	X	X	X	X	A, 7	-	A	A	A
Ideal Yellow 77	A	A	A	A 16	X	-	A	A	A
Imol S150 to S550	X	X	X	-	-	-	A	A	A
Ingersoll Rand SSR Coolant	X	X	X	A 16	X	X	A	A	A
Isocyanates	F	F	F	A 16	X	-	A	-	A
Isooctane	X	F	F	A 16	X	-	A	A	A
Isopar H	X	X	X	X	X	-	A	A	A
Isopropyl Alcohol	F	F	F	A 16	F	-	F	A	A
Jayflex DIDP	X	X	X	X	A	-	A	A	A
JP3 and JP4	X	A,3	A,3	-	X	A(2)	A	A	A
JP5	X	A,3	A,3	F 16,3	X	A(2)	A	A	A
JP9	X	X	X	X	X	-	A	-	A
Kaeser 150P, 175P, 325R, 687R	X	X	X	A 16	X	-	A	A	A
Kerosene	X	A	A	F 15	X	A	A	A	A
KSL-214, 219, 220, 222	X	X	X	A 16	X	-	A	A	A
Lacquer	X	X	X	A 16	X	-	X	A	A
Lacquer Solvents	X	X	X	A 16	X	-	X	A	A
Lactic Acids	X	X	X	X	X	X	X	X	A
Lindol HF	X	X	X	A 16	A	-	A	A	A
Linseed Oil	A	A	A	A 16	A	-	A	A	A
LP-Gas		See 13				-	A	A	A
Magnesium Chloride	A	A	A	A 16	A	-	X	X	X
Magnesium Hydroxide	F	F	F	A 16	A	-	F	F	F
Magnesium Sulfate	A	A	A	A 16	A	-	A	F	A
Mercaptans	X	X	X	X	X	-	-	-	-
Methane		See 14				-	A	A	A
Methanol	F	F	F	A 16	F	-	F	A	A
Methyl Alcohol	F	F	F	A 16	F	-	F	A	A
Methyl Chloride	X	X	X	A 16	X	-	A	A	A
Methyl Ethyl Ketone (MEK)	X	X	X	A 16	X	-	F	A	A
Methyl Isopropyl-Ketone	X	X	X	X	X	-	F	A	A
Metsafe FR303, FR310, FR315, FR330, FR350	X	X	X	X	X	F	A	A	A
Microzol-T46	X	A	A	-	X	-	A	A	A
MIL-B-46176A	X	X	X	X	X	-	X	X	X
MIL-H-46170	X	F	F	A 16	X	-	A	A	A
MIL-H-5606	F	A	A	A 15	X	A	A	A	A
MIL-H-6083	F	A	A	A 16	X	-	A	A	A
MIL-H-7083	F	A	A	A 16	X	-	A	A	A
MIL-H-83282	F	A	A	A 16	X	-	A	A	A
MIL-L-2104, 2104B	F	A	A	A 15	X	A	A	A	A
MIL-L-23699	X	X	X	X	X	X	A	A	A
MIL-L-7808	F	A	A	-	X	-	A	A	A
Mine Guard FR	A	A	A	-	A	-	A	A	A
Mineral Oil	A	A	A	F 15	X	A	A	A	A
Mineral Spirits	8	8	8	8	X	-	A	A	A
Mobil Aero HFE	F	A	A	F 15	X	A	A	A	A
Mobil DTE 11M, 13M, 15M, 16M, 18M, 19M	F	A	A	A 15	X	A	A	A	A
Mobil DTE 22, 24, 25, 26	F	A	A	A 15	X	A	A	A	A
Mobil EAL 224H	X	A	A	X	-	-	A	A	A
Mobil EAL Artic 10, 15, 22,32, 46, 68, 100	X	X	X	X	X	X	A	A	A
Mobil Glygoyle 11, 22, 30, 80	A	A	A	-	X	-	A	A	A
Mobil HFA	F	A	A	A 16	X	-	A	A	A
Mobil Jet 2	X	F	F	A 16	X	-	A	A	A
Mobil Nyvac 20, 30, 200, FR	F	A	A	A	A	F	A	A	A
Mobil Rarus 824, 826, 827	X	X	X	A 16	X	X	A	A	A
Mobil SHC 600 Series	F	A	A	A 16	X	-	A	A	A
Mobil SHC 800 Series	F	A	A	A 16	X	-	A	A	A
Mobil SHL 624	-	A	A	A 16	X	-	A	A	A
Mobil Vactra Oil	A	A	A	F 15	X	A	A	A	A
Mobil XRL 1618B	X	X	X	X	A, 7	F	A	A	A
Mobilfluid 423	F	A	A	A 15	X	A	A	A	A
Mobilgear SHC 150, 220, 320, 460, 680	F	F	F	A 16	X	-	A	A	A
Mobilrama 525	A	A	A	F 15	X	A	A	A	A
Molub-Alloy 890	X	X	X	A 16	X	-	A	A	A
Moly Lube „HF“ 902	F	F	F	F 15	X	A	A	A	A
Monolec 6120 Hydraulic Oil	A	A	A	A 15	X	A	A	A	A
Morpholine (pure additive)	X	X	X	X	X	-	X	X	A
Naptha	X	F	F	A 16	X	-	A	A	A
Napthalene	X	X	X	A 16	X	-	A	A	A
Natural Gas		See 14				-	A	A	A
Nitric Acid	X	X	X	X	X	X	X	X	F

Medium	I	II	III	IV	V	VI	STEEL	BRASS	SS
Nitrobenzene	X	X	X	A 16	X	-	X	X	A
Nitrogen, gas	F, 1	F, 1	F, 1	F 16, 1	F, 1	-	A	A	A
NORPAR 12, 13, 15	8	8	8	8	X	-	A	A	A
Nuto H 46, 68	A	A	A	A 15	X	A	A	A	A
Nyvac 20, 30, 200, FR	F	A	A	A	A	F	A	A	A
Nyvac Light	X	X	X	-	A	-	A	A	A
Oceanic HW	F	A	A	A	X	F	A	A	A
Oxygen, gas	X	X	X	X	X	-	X	A	A
Ozone	F	F	F	-	A	-	A	A	A
Pacer SLC 150, 300, 500, 700	X	X	X	A 16	X	-	A	A	A
Pennzbell AWX	F	A	A	F 15	X	A	A	A	A
Perchloroethylene	X	X	X	X	X	-	F	X	A
Petroleum Ether	X	F	F	F 15	X	A	A	A	A
Petroleum Oils	A	A	A	A 15	X	A	A	A	A
Phenol (Carbolic Acid)	X	X	X	A 16	X	X	X	F	A
Phosphate Ester Blends	X	X	X	X	X	F	A	A	A
Phosphate Esters	X	X	X	X	A, 7	-	A	A	A
Phosphoric Acid	X	X	X	X	X	X	X	X	F
Plurasafe P 1000, 1200	F	A	A	A	F	F	A	A	A
Polyalkylene Glycol	A	F	F	-	X	-	A	A	A
Polyol Ester	X	F	A	X	X	-	A	A	A
Potassium Chloride	A	A	A	A 16	A	-	X	F	F
Potassium Hydroxide	X	X	X	A 16	A	-	6	X	A
Potassium Sulfate	A	A	A	A 16	A	-	A	A	A
Propane		See 13				-	A	A	A
Propylene Glycol	F	A	A	A 16	A	-	F	F	F
Pydraul 10-E, 29-E, 50-E, 65-E, 90-E, 115-E	X	X	X	X	A, 7	F	A	A	A
Pydraul 230-C, 312-C, 68-S	X	X	X	X	A, 7	F	A	A	A
Pydraul 60, 150, 625, F9	X	X	X	X	A, 7	-	A	A	A
Pydraul 90, 135, 230, 312, 540, MC	X	X	X	X	X	-	A	A	A
Pydraul A-200	X	X	X	A 16	X	-	A	A	A
Pyro Gard 43, 230, 630	X	X	X	X	X	-	A	A	A
Pyro Gard C, D, R, 40S, 40W	F	A	A	F 16	X	A	A	A	A
Pyro Guard 53, 55, 51, 42	X	X	X	X	A, 7	-	A	A	A
Quintolubric 700	A	A	A	A 16	A	-	A	F	A
Quintolubric 807-SN	F	A	A	-	X	-	A	A	A
Quintolubric 822, 833	X	F, 5	A, 5	X	X	X	A	A	A
Quintolubric 822-68EHC (71°C, 160°F maximum)	X	F, 5	A, 5	-	-	-	A	A	A
Quintolubric 888	X	F, 5	A, 5	X	X	-	A	A	A
Quintolubric 957, 958	F	A	A	A	A	F	A	A	A
Quintolubric N822-300	~	~	A	-	-	-	A	A	A
Rando	A	A	A	A 15	X	A	A	A	A
Rayco 782	X	F	A	X	X	-	X	X	X
Refrigerant 124		See 4				X	A	A	A
Refrigerant Freon 113, 114	X	X	X	X	X	X	A	A	A
Refrigerant Freon 12		See 4		X		X	A	A	A
Refrigerant Freon 22		See 4		X		X	A	A	A
Refrigerant Freon 502		See 4		X		X	A	A	A
Refrigerant HFC134A		See 4		X		X	A	A	A
Reolube Turbofluid 46	X	X	X	X	A, 7	-	A	A	A
Rotella	A	A	A	A 15	X	A	A	A	A
Royal Bio Guard 3032, 3046, 3068, 3100	X	~	A	X	X	X	A	A	A
Royco 2200, 2210, 2222, 2232, 2246, 2268	X	X	X	X	X	X	A	A	A
Royco 4032, 4068, 4100, 4150	X	X	X	A 16	X	X	A	A	A
Royco 756, 783	A	A	A	A 15	X	A	A	A	A
Royco 770	X	F	F	F 16	X	-	A	A	A
RTV Silicone Adhesive Sealants	X	X	X	X	X	-	A	A	A
Safco-Safe T10, T20	-	-	-	-	A	-	F	F	A
Safety-Kleen ISO 32, 46, 68 hydraulic oil	F	A	A	-	X	A	A	A	A
Safety-Kleen Solvent	8	8	8	8	X	-	A	A	A
Santoflex 13	F	F	F	-	F	-	A	A	A
Santosafe 300	X	X	X	-	X	-	A	A	A
Santosafe W/G 15 to 30	-	-	-	A 16	A	-	A	A	A
Sea Water	F	F	F	A 16	A	-	X	F	A
Sewage	F	F	F	A 16	F	-	X	F	A
Shell 140 Solvent	8	8	8	8	X	-	A	A	A
Shell Clavus HFC 68	X	X	X	X	X	X	A	A	A
Shell Comptella Oil	F	F	F	A 15	X	A	A	A	A
Shell Comptella Oil S 46, 68	F	F	F	A 15	X	A	A	A	A
Shell Comptella Oil SM	F	F	F	A 15	X	A	A	A	A
Shell Diala A, (R) Oil AX	F	A	A	F 15	X	A	A	A	A
Shell FRM	-	-	-	-	X	-	A	A	A
Shell IRUS 902, 905	A	A	A	-	A	-	A	A	A
Shell Pella-A	A	A	A	A 16	X	-	A	A	A
Shell Tellus	F	A	A	A 15	X	A	A	A	A
Shell Thermia Oil C	A	A	A	A 15	X	A	A	A	A

Medium	I	II	III	IV	V	VI	STEEL	BRASS	SS
Shell Turbo R	X	F	F	A 16	X	X	A	A	A
SHF 220, 300, 450	X	X	A	X	X	X	A	A	A
Silicate Esters	A	F	F	A 16	X	-	A	A	A
Silicone Oils	A	A	A	-	-	-	A	A	A
Silicone Sealants	X	X	X	X	X	-	A	A	A
Skydrol 500B-4, LD-4	X	X	X	X	A, 7	F	A	A	A
Soap Solutions	X	F	F	F 16	A	-	A	A	A
Soda Ash, Sodium Carbonate	A	A	A	A 16	A	-	A	F	A
Sodium Bisulfate	F	F	F	A 16	A	-	F	A	F
Sodium Chloride	F	F	F	A 16	A	-	X	F	A
Sodium Hydroxide	X	X	X	A 16	A	-	A	X	A
Sodium Hypochlorite	F	F	F	X	F	-	X	X	X
Sodium Nitrate	F	F	F	A 16	A	-	A	F	A
Sodium Peroxide	X	X	X	X	A	-	X	X	A
Sodium Silicate	A	A	A	A 16	A	-	A	A	A
Sodium Sulfate	A	A	A	A 16	A	-	A	A	A
Soybean Oil	F	A	A	A 16	A	-	A	A	A
SSR Coolant	X	X	X	A 16	X	X	A	A	A
Steam	X	X	X	X	X	-	F	A	A
Stoddard Solvent	8	8	8	8	X	-	A	A	A
Sulfur Chloride	X	X	X	A 16	X	-	X	X	X
Sulfur Dioxide	X	X	X	X	F	-	X	F	F
Sulfur Trioxide	X	X	X	A 16	F	-	X	X	X
Sulfuric Acid (0% to 30% room temperature)	F, 6	F, 6	F, 6	X	F, 6	-	6	X	6
Summa-20, Rotor, Recip	X	X	X	A 16	X	-	A	A	A
Summit DSL-32,68,100,125	X	X	X	A 16	X	-	A	A	A
Sun Minesafe, Sun Safe	X	F	F	A 16	X	-	A	A	A
Sundex 8125	X	F	F	-	A	-	A	A	A
Suniso 3GS	A	A	A	A 15	X	A	A	A	A
Sun-Vis 722	X	F	F	-	X	-	A	A	A
Super Hydraulic Oil 100, 150, 220	A	A	A	A 15	X	A	A	A	A
SUVA MP 39, 52, 66	X	X	X	X	X	X	A	A	A
SYNCON Oil	X	X	X	X	X	-	A	A	A
Syndale 2820	X	F	F	-	-	-	A	A	A
Synesstic 32,68,100	X	X	X	X	X	X	A	A	A
Syn-Flo 70,90	X	X	X	A 16	X	-	A	A	A
SYN-O-AD 8478	X	X	X	X	A, 7	F	A	A	A
Tannic Acid	F	A	A	A 16	A	X	X	F	X
Tar	F	F	F	A 16	X	-	X	F	A
Tellus (Shell)	F	A	A	A 15	X	A	A	A	A
Texaco 760 Hydrafluid	-	-	-	-	X	-	A	A	A
Texaco 766, 763 (200 - 300)	-	-	-	-	A	-	F	F	A
Texaco A-Z Oil	A	A	A	F 15	X	A	A	A	A
Texaco Spindura Oil 22	F	F	F	F 15	X	A	A	A	A
Texaco Way Lubricant 68	A	A	A	A 15	X	A	A	A	A
Thanol-R-650-X	X	F	F	-	X	-	A	A	A
Thermanol 60	X	X	X	X	X	-	A	A	A
Toluene, Toluol	X	X	X	X	X	-	A	A	A
Transmission Oil	A	A	A	A 15	X	A	A	A	A
Tribol 1440	X	F	F	X	X	F	A	A	A
Trichloroethylene	X	X	X	A 16	X	-	X	A	A
Trim-Sol	F	A	A	A 16	X	-	A	A	A
Turbinol 50, 1122, 1223	X	X	X	X	A, 7	-	A	A	A
Turpentine	X	X	X	A 16	X	-	A	A	A
Ucon Hydrolubes	F	A	A	A	A	F	A	A	A
UltraChem 215,230,501,751	X	X	X	A 16	X	-	A	A	A
Univis J26	A	A	A	A 15	X	A	A	A	A
Unleaded Gasoline		See 9				-	A	A	A
Unocal 66/3 Mineral Spirits	8	8	8	8	X	-	A	A	A
Urea	F	F	F	A 16	F	-	F	-	F
Urethane Formulations	A	A	A	A 16	-	-	A	A	A
Van Straaten 902	A	A	A	A 16	X	-	A	A	A
Varnish	X	X	X	A 16	X	-	F	F	A
Varsol	8	F	F	8	X	-	A	A	A
Versilube F44, F55		A	A	A 16	-	-	A	A	A
Vinegar	X	X	X	A 16	A	-	F	X	A
Vital 29, 4300, 5230, 5310	X	X	X	X	X	-	A	A	A
Volt Esso 35	A	A	A	A 16	X	-	A	A	A
Water	F	A	A	A	A	A	F	A	A
Water / Glycols	A	A	A	A	A	F	A	F	A
Xylene, Xylol	X	X	X	X	X	-	A	A	A
Zerol 150	A	A	A	A 15	X	A	A	A	A
Zinc Chloride	A	A	A	X	A	-	X	X	F
Zinc Sulfate	A	A	A	X	A	-	X	A	A

Parker Safety Guide for Selecting and Using Hose, Tubing, Fittings and Related Accessories

Parker Publication No. 4400-B.1-EUR

Revised: March, 2005



WARNING

Failure or improper selection or improper use of hose, tubing, fittings, assemblies or related accessories ("Products") can cause death, personal injury and property damage. Possible consequences of failure or improper selection or improper use of these Products include but are not limited to:

- Fittings thrown off at high speed.
- High velocity fluid discharge.
- Explosion or burning of the conveyed fluid.
- Electrocutation from high voltage electric powerlines.
- Contact with suddenly moving or falling objects that are controlled by the conveyed fluid.
- Injections by high-pressure fluid discharge.
- Dangerously whipping Hose.
- Contact with conveyed fluids that may be hot, cold, toxic or otherwise injurious.
- Sparking or explosion caused by static electricity buildup or other sources of electricity.
- Sparking or explosion while spraying paint or flammable liquids.
- Injuries resulting from inhalation, ingestion or exposure to fluids.

Before selecting or using any of these Products, it is important that you read and follow the instructions below. Only Hose from Parker's Stratoflex Products Division is approved for in flight aerospace applications, and no other Hose can be used for such in flight applications.

1.0 GENERAL INSTRUCTIONS

1.1 Scope

This safety guide provides instructions for selecting and using (including assembling, installing, and maintaining) these Products. For convenience, all rubber and/or thermoplastic products commonly called "hose" or "tubing" are called "Hose" in this safety guide. All assemblies made with Hose are called "Hose Assemblies". All products commonly called "fittings" or "couplings" are called "Fittings". All related accessories (including crimping and swaging machines and tooling) are called "Related Accessories". This safety guide is a supplement to and is to be used with, the specific Parker publications for the specific Hose, Fittings and Related Accessories that are being considered for use.

1.2 Fail-Safe

Hose, and Hose Assemblies and Fittings can and do fail without warning for many reasons. Design all systems and equipment in a failsafe mode, so that failure of the Hose or Hose Assembly or Fitting will not endanger persons or property.

1.3 Distribution

Provide a copy of this safety guide to each person that is responsible for selecting or using Hose and Fitting products. Do not select or use Parker Hose or Fittings without thoroughly reading and understanding this safety guide as well as the specific Parker publications for the products considered or selected.

1.4 User Responsibility

Due to the wide variety of operating conditions and applications for Hose and Fittings, Parker and its distributors do not represent or warrant that any particular Hose or Fitting is suitable for any specific end use system. This safety guide does not analyze all technical parameters that must be considered in selecting a product. The user, through its own analysis and testing, is solely responsible for:

- Making the final selection of the Hose and Fitting.
- Assuring that the user's requirements are met and that the application presents no health or safety hazards.
- Providing all appropriate health and safety warnings on the equipment on which the Hose and Fittings are used.
- Assuring compliance with all applicable government and industry standards.

1.5 Additional Questions

Call the appropriate Parker technical service department if you have any questions or require any additional information. See the Parker publication for the product being considered or used, or call 00-800-2727-5374, or go to www.parker.com, for telephone numbers of the appropriate technical service department.

2.0 HOSE AND FITTING SELECTION INSTRUCTIONS

2.1 Electrical Conductivity

Certain applications require that the Hose be nonconductive to prevent electrical current flow. Other applications require the Hose and the Fitting and the Hose/Fitting interface to be sufficiently conductive to drain off static electricity. Extreme care must be exercised when selecting Hose and Fittings for these or any other applications in which electrical conductivity or nonconductivity is a factor. The electrical conductivity or nonconductivity of Hose and Fittings is dependent upon many factors and may be susceptible to change. These factors include but are not limited to the various materials used to make the Hose and the Fittings, Fitting finish (some Fitting finishes are electrically conductive while others are nonconductive), manufacturing methods (including moisture control), how the Fittings contact the Hose, age and amount of deterioration or damage or other changes, moisture content of the Hose at any particular time, and other factors. The following are considerations for electrically nonconductive and conductive Hose. For other applications consult the individual catalog pages and the appropriate industry or regulatory standards for proper selection.

2.1.1 Electrically Nonconductive Hose

Certain applications require that the Hose be nonconductive to prevent electrical current flow or to maintain electrical isolation. For these applications that require Hose to be electrically nonconductive, including but not limited to applications near high voltage electric lines, only special nonconductive Hose can be used. The manufacturer of the equipment in which the nonconductive Hose is to be used must be consulted to be certain that the Hose and Fittings that are selected are proper for the application. Do not use any Parker Hose or Fitting for any such application requiring nonconductive Hose, including but not limited to applications near high voltage electric lines, unless (i) the application is expressly approved in the Parker technical publication for the product, (ii) the Hose is marked "nonconductive", and (iii) the manufacturer of the equipment on which the Hose is to be used specifically approves the particular Parker Hose and Fitting for such use.

2.1.2 Electrically Conductive Hose

Parker manufactures special Hose for certain applications that require electrically conductive Hose. Parker manufactures special Hose for conveying paint in airless paint spraying applications. This Hose is labeled "Electrically Conductive Airless Paint Spray Hose" on its layline and packaging. This Hose must be properly connected to the appropriate Parker Fittings and properly grounded in order to dissipate dangerous static charge buildup, which occurs in all airless paint spraying applications. Do not use any other Hose for airless paint spraying, even if electrically conductive. Use of any other Hose or failure to properly connect the Hose can cause a fire or an explosion resulting in death, personal injury, and property damage. Parker manufactures a special Hose for certain compressed natural gas ("CNG") applications where static electricity buildup may occur. Parker CNG Hose assemblies comply with AGA Requirements 1-93, "Hoses for Natural Gas Vehicles and Fuel Dispensers". This Hose is labeled "Electrically Conductive for CNG Use" on its layline and packaging. This Hose must be properly connected to the appropriate Parker Fittings and properly grounded in order to dissipate dangerous static charge buildup, which occurs in, for example, high velocity CNG dispensing or transfer. Do not use any other Hose for CNG applications where static charge buildup may occur, even if electrically conductive. Use of other Hoses in CNG applications or failure to properly connect or ground this Hose can cause a fire or an explosion resulting in death, personal injury, and property damage. Care must also be taken to protect against CNG permeation through the Hose wall. See section 2.6, Permeation, for more information. Parker CNG Hose is intended for dispenser and vehicle use at a maximum temperature of 82°C / 180°F. Parker CNG Hose should not be used in confined spaces or unventilated areas or areas exceeding 82°C / 180°F. Final assemblies must be tested for leaks. CNG Hose Assemblies should be tested on a monthly basis for conductivity per AGA 1-93. Parker manufactures special Hose for aerospace in flight applications. Aerospace in flight applications employing Hose to transmit fuel, lubricating fluids and hydraulic fluids require a special Hose with a conductive inner tube. This Hose for in flight applications is available only from Parker's Stratoflex Products Division. Do not use any other Parker Hose for in flight applications, even if electrically conductive. Use of other Hoses for in flight applications or failure to properly connect or ground this Hose can cause a fire or an explosion resulting in death, personal injury, and property damage. These Hose assemblies for in flight applications must meet all applicable aerospace industry, aircraft engine, and aircraft requirements.

2.2 Pressure

Hose selection must be made so that the published maximum recommended working pressure of the Hose is equal to or greater than the maximum system pressure. Surge pressures or peak transient pressures in the system must be below the published maximum working pressure for the Hose. Surge pressures and peak pressures can usually only be determined by sensitive electrical instrumentation that measures and indicates pressures at millisecond intervals. Mechanical pressure gauges indicate only average pressures and cannot be used to determine surge pressures or peak transient pressures. Published burst pressure ratings for Hose is for manufacturing test purposes only and is no indication that the Product can be used in applications at the burst pressure or otherwise above the published maximum recommended working pressure.

2.3 Suction

Hoses used for suction applications must be selected to ensure that the Hose will withstand the vacuum and pressure of the system. Improperly selected Hose may collapse in suction application.

2.4 Temperature

Be certain that fluid and ambient temperatures, both steady and transient, do not exceed the limitations of the Hose. Temperatures below and above the recommended limit can degrade Hose to a point where a failure may occur and release fluid. Properly insulate and protect the Hose Assembly when routing near hot objects (e.g. manifolds). Do not use any Hose in any application where failure of the Hose could result in the conveyed

fluids (or vapors or mist from the conveyed fluids) contacting any open flame, molten metal, or other potential fire ignition source that could cause burning or explosion of the conveyed fluids or vapors.

2.5 Fluid Compatibility

Hose Assembly selection must assure compatibility of the Hose tube, cover, reinforcement, and Fittings with the fluid media used. See the fluid compatibility chart in the Parker publication for the product being considered or used. This information is offered only as a guide. Actual service life can only be determined by the end user by testing under all extreme conditions and other analysis. Hose that is chemically compatible with a particular fluid must be assembled using Fittings and adapters containing likewise compatible seals.

2.6 Permeation

Permeation (that is, seepage through the Hose) will occur from inside the Hose to outside when Hose is used with gases, liquid and gas fuels, and refrigerants (including but not limited to such materials as helium, diesel fuel, gasoline, natural gas, or LPG). This permeation may result in high concentrations of vapors which are potentially flammable, explosive, or toxic, and in loss of fluid. Dangerous explosions, fires, and other hazards can result when using the wrong Hose for such applications. The system designer must take into account the fact that this permeation will take place and must not use Hose if this permeation could be hazardous. The system designer must take into account all legal, government, insurance, or any other special regulations which govern the use of fuels and refrigerants. Never use a Hose even though the fluid compatibility is acceptable without considering the potential hazardous effects that can result from permeation through the Hose Assembly. Permeation of moisture from outside the Hose to inside the Hose will also occur in Hose assemblies, regardless of internal pressure. If this moisture permeation would have detrimental effects (particularly, but not limited to refrigeration and air conditioning systems), incorporation of sufficient drying capacity in the system or other appropriate system safeguards should be selected and used.

2.7 Size

Transmission of power by means of pressurized fluid varies with pressure and rate of flow. The size of the components must be adequate to keep pressure losses to a minimum and avoid damage due to heat generation or excessive fluid velocity.

2.8 Routing

Attention must be given to optimum routing to minimize inherent problems (kinking or flow restriction due to Hose collapse, twisting of the Hose, proximity to hot objects or heat sources).

2.9 Environment

Care must be taken to insure that the Hose and Fittings are either compatible with or protected from the environment (that is, surrounding conditions) to which they are exposed. Environmental conditions including but not limited to ultraviolet radiation, sunlight, heat, ozone, moisture, water, salt water, chemicals, and air pollutants can cause degradation and premature failure.

2.10 Mechanical Loads

External forces can significantly reduce Hose life or cause failure. Mechanical loads which must be considered include excessive flexing, twist, kinking, tensile or side loads, bend radius, and vibration. Use of swivel type Fittings or adapters may be required to insure no twist is put into the Hose. Unusual applications may require special testing prior to Hose selection.

2.11 Physical Damage

Care must be taken to protect Hose from wear, snagging, kinking, bending smaller than minimum bend radius, and cutting, any of which can cause premature Hose failure. Any Hose that has been kinked or bent to a radius smaller than the minimum bend radius, and any Hose that has been cut or is cracked or is otherwise damaged, should be removed and discarded.

2.12 Proper End Fitting

See instructions 3.2 through 3.5. These recommendations may be substantiated by testing to industry standards such as EN853, EN854, EN857, ISO17165-2, SAE J517 for hydraulic applications, or MIL-A-5070, AS1339, or AS3517 for Hoses from Parker's Stratoflex Products Division for aerospace applications.

2.13 Length

When establishing a proper Hose length, motion absorption, Hose length changes due to pressure, and Hose and machine tolerances and movement must be considered.

2.14 Specifications and Standards

When selecting Hose and Fittings, government, industry, and Parker specifications and recommendations must be reviewed and followed as applicable.

2.15 Hose Cleanliness

Hose components may vary in cleanliness levels. Care must be taken to insure that the Hose Assembly selected has an adequate level of cleanliness for the application.

2.16 Fire Resistant Fluids

Some fire resistant fluids that are to be conveyed by Hose require use of the same type of Hose as used with petroleum base fluids. Some such fluids require a special Hose, while a few fluids will not work with any Hose at all. See instructions 2.5 and 1.5. The wrong Hose may fail after a very short service. In addition, all liquids but pure water may burn fiercely under certain conditions, and even pure water leakage may be hazardous.

2.17 Radiant Heat

Hose can be heated to destruction without contact by such nearby items as hot manifolds or molten metal. The same heat source may then initiate a fire. This can occur despite the presence of cool air around the Hose.

2.18 Welding or Brazing

When using a torch or arc-welder in close proximity to hydraulic lines, the hydraulic lines should be removed or shielded with appropriate fire resistant materials. Flame or weld spatter could burn through the Hose and possibly ignite escaping fluid resulting in a catastrophic failure. Heating of plated parts, including Hose Fittings and adapters, above 450°F (232°C) such as during welding, brazing, or soldering may emit deadly gases.

2.19 Atomic Radiation

Atomic radiation affects all materials used in Hose assemblies. Since the long-term effects may be unknown, do not expose Hose assemblies to atomic radiation.

2.20 Aerospace Applications

The only Hose and Fittings that may be used for in flight aerospace applications are those available from Parker's Stratoflex Products Division. Do not use any other Hose or Fittings for in flight applications. Do not use any Hose or Fittings from Parker's Stratoflex Products Division with any other Hose or Fittings, unless expressly approved in writing by the engineering manager or chief engineer of Stratoflex Products Division and verified by the user's own testing and inspection to aerospace industry standards.

2.21 Unlocking Couplings

Ball locking couplings or other couplings with disconnect sleeves can unintentionally disconnect if they are dragged over obstructions or if the sleeve is bumped or moved enough to cause disconnect. Threaded couplings should be considered where there is a potential for accidental uncoupling.

3.0 HOSE AND FITTING ASSEMBLY AND INSTALLATION INSTRUCTIONS

3.1 Component Inspection

Prior to assembly, a careful examination of the Hose and Fittings must be performed. All components must be checked for correct style, size, catalog number, and length. The Hose must be examined for cleanliness, obstructions, blisters, cover looseness, kinks, cracks, cuts or any other visible defects. Inspect the Fitting and sealing surfaces for burrs, nicks, corrosion or other imperfections. Do NOT use any component that displays any signs of nonconformance.

3.2 Hose and Fitting Assembly

Do not assemble a Parker Fitting on a Parker Hose that is not specifically listed by Parker for that Fitting, unless authorized in writing by the engineering manager or chief engineer of the appropriate Parker division. Do not assemble a Parker Fitting on another manufacturer's Hose or a Parker Hose on another manufacturer's Fitting unless (i) the engineering manager or chief engineer of the appropriate Parker division approves the Assembly in writing or that combination is expressly approved in the appropriate Parker literature for the specific Parker product, and (ii) the user verifies the Assembly and the application through analysis and testing. For Parker Hose that does not specify a Parker Fitting, the user is solely responsible for the selection of the proper Fitting and Hose Assembly procedures. See instruction 1.4. The Parker published instructions must be followed for assembling the Fittings on the Hose. These instructions are provided in the Parker Fitting catalog for the specific Parker Fitting being used, or by calling 00-800-2727-5374, or at www.parker.com.

3.3 Related Accessories

Do not crimp or swage any Parker Hose or Fitting with anything but the listed swage or crimp machine and dies in accordance with Parker published instructions. Do not crimp or swage another manufacturer's Fitting with a Parker crimp or swage die unless authorized in writing by the engineering manager or chief engineer of the appropriate Parker division.

3.4 Parts

Do not use any Parker Fitting part (including but not limited to socket, shell, nipple, or insert) except with the correct Parker mating parts, in accordance with Parker published instructions, unless authorized in writing by the engineering manager or chief engineer of the appropriate Parker division.

3.5 Reusable/Permanent

Do not reuse any field attachable (reusable) Hose Fitting that has blown or pulled off a Hose. Do not reuse a Parker permanent Hose Fitting (crimped or swaged) or any part thereof. Complete Hose Assemblies may only be reused after proper inspection under section 4.0. Do not assemble Fittings to any previously used hydraulic Hose that was in service, for use in a fluid power application.

3.6 Pre-Installation Inspection

Prior to installation, a careful examination of the Hose Assembly must be performed. Inspect the Hose Assembly for any damage or defects. Do NOT use any Hose Assembly that displays any signs of nonconformance.

3.7 Minimum Bend Radius

Installation of a Hose at less than the minimum listed bend radius may significantly reduce the Hose life. Particular attention must be given to preclude sharp bending at the Hose to Fitting juncture. Any bending during installation at less than the minimum bend radius must be avoided. If any Hose is kinked during installation, the Hose must be discarded.

3.8 Twist Angle and Orientation

Hose Assembly installation must be such that relative motion of machine components does not produce twisting.

3.9 Securement

In many applications, it may be necessary to restrain, protect, or guide the Hose to protect it from damage by unnecessary flexing, pressure surges, and contact with other mechanical components. Care must be taken to insure such restraints do not introduce additional stress or wear points.

3.10 Proper Connection of Ports

Proper physical installation of the Hose Assembly requires a correctly installed port connection insuring that no twist or torque is transferred to the Hose when the Fittings are being tightened or otherwise during use.

3.11 External Damage

Proper installation is not complete without insuring that tensile loads, side loads, kinking, flattening, potential abrasion, thread damage, or damage to sealing surfaces are corrected or eliminated. See instruction 2.10.

3.12 System Checkout

All air entrapment must be eliminated and the system pressurized to the maximum system pressure (at or below the Hose maximum working pressure) and checked for proper function and freedom from leaks. Personnel must stay out of potential hazardous areas while testing and using.

3.13 Routing

The Hose Assembly should be routed in such a manner so if a failure does occur, the escaping media will not cause personal injury or property damage. In addition, if fluid media comes in contact with hot surfaces, open flame, or sparks, a fire or explosion may occur. See section 2.4.

4.0 HOSE AND FITTING MAINTENANCE AND REPLACEMENT INSTRUCTIONS

4.1

Even with proper selection and installation, Hose life may be significantly reduced without a continuing maintenance program. The severity of the application, risk potential from a possible Hose failure, and experience with any Hose failures in the application or in similar applications should determine the frequency of the inspection and the replacement for the Products so that Products are replaced before any failure occurs. A maintenance program must be established and followed by the user and, at minimum, must include instructions 4.2 through 4.7.

4.2 Visual Inspection Hose/Fitting

Any of the following conditions require immediate shut down and replacement of the Hose Assembly:

- Fitting slippage on Hose,
- Damaged, cracked, cut or abraded cover (any reinforcement exposed);
- Hard, stiff, heat cracked, or charred Hose;
- Cracked, damaged, or badly corroded Fittings;
- Leaks at Fitting or in Hose;
- Kinked, crushed, flattened or twisted Hose; and
- Blistered, soft, degraded, or loose cover.

4.3 Visual Inspection All Other

The following items must be tightened, repaired, corrected or replaced as required:

- Leaking port conditions;
- Excess dirt buildup;
- Worn clamps, guards or shields; and
- System fluid level, fluid type, and any air entrapment.

4.4 Functional Test

Operate the system at maximum operating pressure and check for possible malfunctions and leaks. Personnel must avoid potential hazardous areas while testing and using the system. See section 2.2.

4.5 Replacement Intervals

Hose assemblies and elastomeric seals used on Hose Fittings and adapters will eventually age, harden, wear and deteriorate under thermal cycling and compression set. Hose Assemblies and elastomeric seals should be inspected and replaced at specific replacement intervals, based on previous service life, government or industry recommendations, or when failures could result in unacceptable downtime, damage, or injury risk. See section 1.2.

4.6 Hose Inspection and Failure

Hydraulic power is accomplished by utilizing high-pressure fluids to transfer energy and do work. Hoses, Fittings, and Hose Assemblies all contribute to this by transmitting fluids at high pressures. Fluids under pressure can be dangerous and potentially lethal and, therefore, extreme caution must be exercised when working with fluids under pressure and handling the Hoses transporting the fluids. From time to time, Hose Assemblies will fail if they are not replaced at proper time intervals. Usually these failures are the result of some form of misapplication, abuse, wear, or failure to perform proper maintenance. When Hoses fail, generally the high-pressure fluids inside escape in a stream which may or may not be visible to the user. Under no circumstances should the user attempt to locate the leak by "feeling" with their hands or any other part of their body. High-pressure fluids can and will penetrate the skin and cause severe tissue damage and possibly loss of limb. Even seemingly minor hydraulic fluid injection injuries must be treated immediately by a physician with knowledge of the tissue damaging properties of hydraulic fluid. If a Hose failure occurs, immediately shut down the equipment and leave the area until pressure has been completely released from the Hose Assembly. Simply shutting down the hydraulic pump may or may not eliminate the pressure in the Hose Assembly. Many times check valves, etc., are employed in a system and can cause pressure to remain in a Hose Assembly even when pumps or equipment are not operating. Tiny holes in the Hose, commonly known as pinholes, can eject small, dangerously powerful but hard to see streams of hydraulic fluid. It may take several minutes or even hours for the pressure to be relieved so that the Hose Assembly may be examined safely. Once the pressure has been reduced to zero, the Hose Assembly may be taken off the equipment and examined. It must always be replaced if a failure has occurred. Never attempt to patch or repair a Hose Assembly that has failed. Consult the nearest Parker distributor or the appropriate Parker division for Hose Assembly replacement information. Never touch or examine a failed Hose Assembly unless it is obvious that the Hose no longer contains fluid under pressure. The high-pressure fluid is extremely dangerous and can cause serious and potentially fatal injury.

4.7 Elastomeric seals

Elastomeric seals will eventually age, harden, wear and deteriorate under thermal cycling and compression set. Elastomeric seals should be inspected and replaced.

4.8 Refrigerant gases

Special care should be taken when working with refrigeration systems. Sudden escape of refrigerant gases can cause blindness if the escaping gases contact the eye and can cause freezing or other severe injuries if it contacts any other portion of the body.

4.9 Compressed natural gas (CNG)

Parker CNG Hose Assemblies should be tested after installation and before use, and at least on a monthly basis per AGA 1-93 Section 4.2 "Visual Inspection Hose/Fitting". The recommended procedure is to pressurize the Hose and check for leaks and to visually inspect the Hose for damage.

Caution: Matches, candles, open flame or other sources of ignition shall not be used for Hose inspection. Leak check solutions should be rinsed off after use.

Identifying Fitting Types

In general fittings can be identified by their visual appearance, their sealing surface/ sealing type or by their thread type/form. Viewing the following pages the visual identification will be self explanatory. The sealing mechanism and the method of thread identification however, needs further explanation

Determining Sealing Mechanisms:

- Thread interface
- O-ring
- Matching angle or metal to metal joint
- Mated angle with O-ring

Thread Interface

The sealing is assured by the flattening of the edges of the threads when the male is screwed into the female fitting. Typically the front of the male fittings are narrower than the back of the fittings – often referred to as tapered threads.

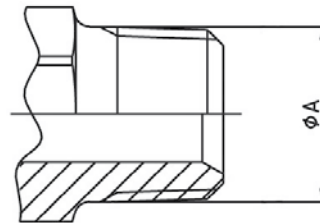

O-ring

The O-ring on the male is compressed against the corresponding female and assures the seal. This type of sealing mechanism should be the preferred choice for high-pressure applications.

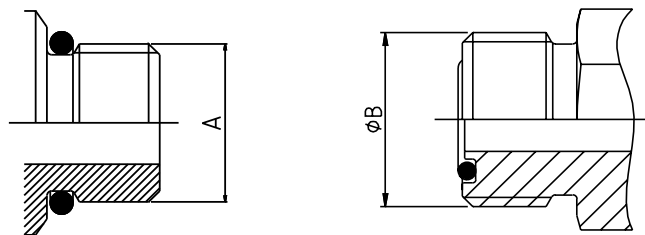

Matching Angle or Metal to Metal Joint

The seal takes place where the two angled faces of the male and corresponding female meet and are wedged into one another by the tightening of the threaded nut.

The sealing surfaces can either be convex or concave (seat) on the male or in the head of the pipe of the female as shown.

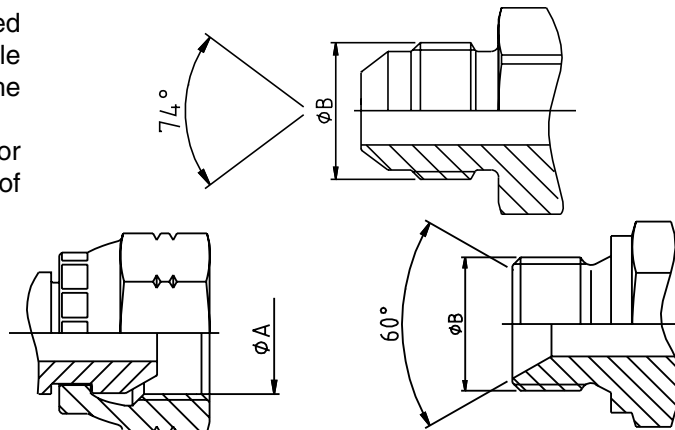

Matching Angle with O-ring

These fittings combine the functionality of both the matching angle seal with the O-ring. The O-ring is in the angled sealing surface of the fitting so that when the threaded male and female are screwed together the sealing surfaces wedge together and at the same time deform the O-ring between them.

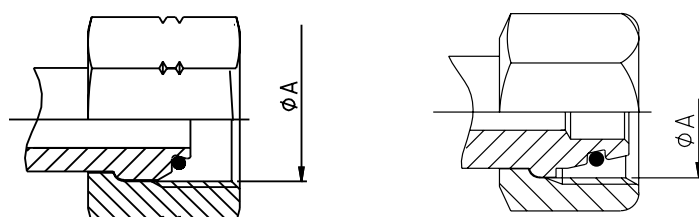

Determining Thread Type

In general the appearance of the threads of various fittings looks similar and hinders the easy identification of the thread. To assure the correct identification, the threads must be measured and compared to the tables listed in the following section.

Thread Gauge

Using a thread gauge, the number of threads per inch can be determined. Holding the gauge and coupling threads in front of a lighted background helps to obtain an accurate measurement.

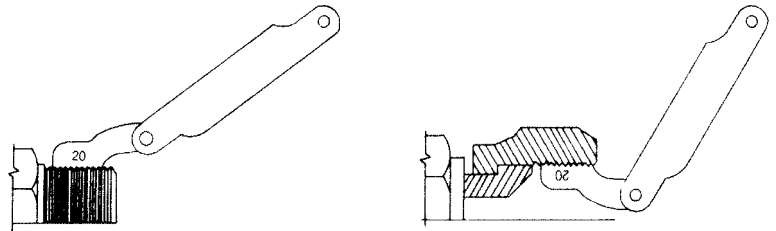

Caliper Measure

A vernier caliper should be used to measure the thread diameter of the largest point. (Outside diameter (O.D.) of male threads – Inside Diameter (I.D.) of female threads.)

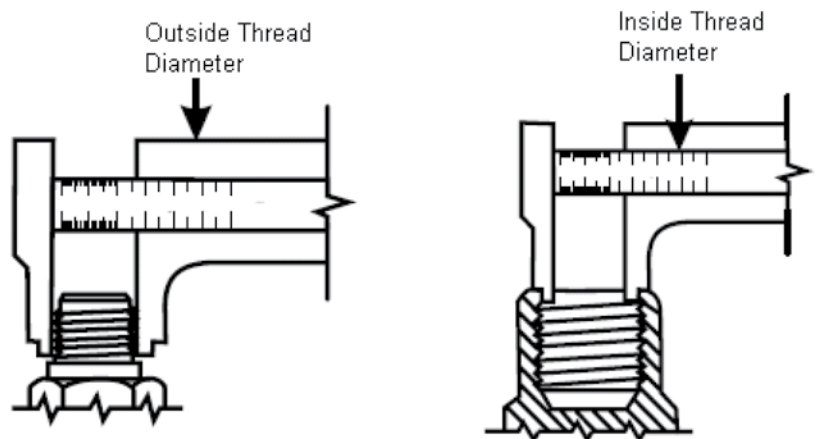

German DIN Hose Fittings (DIN – Deutsches Institut für Normung)

Often referred to as metric fittings these fittings seal using the angled sealing surfaces (metal to metal) or the combination of metal to metal with O-rings.

They are available in **very light (LL)**, **light series (L)** or **heavy series (S)**

The sealing face angles are either 24° with or without O-rings, or 24°/60° universal cones.

Identification is made by measuring the thread size and also the tube outside diameter.

Defined by the outside diameter and the pitch (distance between 2 crests of the thread)
example: M22x1.5 - pitch of 1,5mm

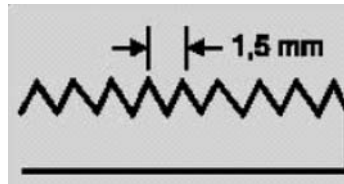

DIN Very Light Series (LL)

The male 60° cone will mate with the female 60° cone only.
The male has a 60° sealing angle (seat) and straight metric thread. The female has a 60° seat and straight metric thread.

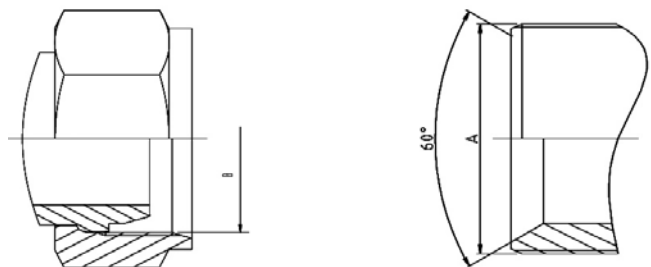

Standard
DIN 20078 Part 3 ¹⁾

Parker end configurations
C0

DN	Metric thread	ØA (mm)	ØB (mm)
20	M30x1.5	30,00	28,50
25	M38x1.5	38,00	36,50
32	M45x1.5	45,00	43,50
40	M52x1.5	52,00	50,50
50	M65x2	65,00	63,00

DIN Light (L) and Heavy Series (S) without O-ring

The male 60° cone will mate with the female universal 24° or 60° cone only.

The male has a 60° sealing angle (seat) and straight metric threads. The female has a 24° and 60° universal seat and straight metric threads.

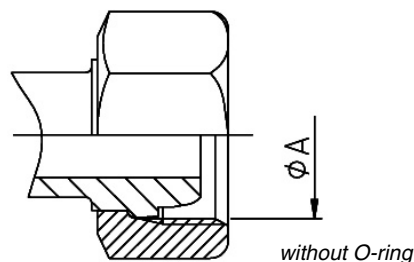

Standard
DIN 20078 Part 2 ¹⁾

(previously known as DIN 20078 A, D & E)

Parker end configurations light series:
C3, C4, C5, C6

(Often also referred to as "Ball nose cones")

¹⁾ obsolete standard, no exact replacement

**DIN 24° Light (L) and Heavy Series (S)
with O-ring**

The male has a 24° sealing angle cone seat with straight metric threads.

The female has a 24° convex cone with O-ring and a swivel straight metric threaded nut.

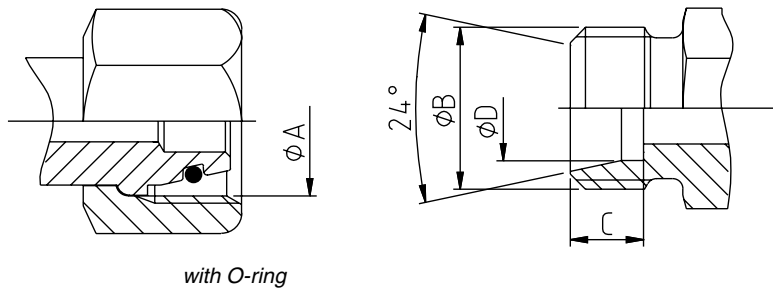

Standard
ISO 12151-2 / ISO 8434-1 & ISO 8434-4
(Previously DIN 20 078 Part 4, 5, 8, 9)

Parker end configurations light series
CA, CE, CF, D0

Parker end configurations heavy series
C9, 0C, 1C, D2

Tube OD	Specif.	Metric thread	ØA (mm)	ØB (mm)	C (mm)	ØD (mm)
6,00	6L	M12X1.5	10,50	12,00	7,00	6,20
6,00	6S	M14X1.5	12,50	14,00	7,00	6,20
8,00	8L	M14x1.5	12,50	14,00	7,00	8,20
8,00	8S	M16x1.5	14,50	16,00	7,00	8,20
10,00	10L	M16x1.5	14,50	16,00	7,00	10,20
10,00	10S	M18x1.5	16,50	18,00	7,50	10,20
12,00	12L	M18x1.5	16,50	18,00	7,00	12,20
12,00	12S	M20x1.5	18,50	20,00	7,50	12,20
14,00	14S	M22x1.5	20,50	22,00	8,00	14,20
15,00	15L	M22x1.5	20,50	22,00	7,00	15,20
16,00	16S	M24x1.5	22,50	24,00	8,50	16,20
18,00	18L	M26x1.5	24,50	26,00	7,50	18,20
20,00	20S	M30x2	27,90	30,00	10,50	20,20
22,00	22L	M30x2	27,90	30,00	7,50	22,20
25,00	25S	M36x2	33,90	36,00	12,00	25,20
28,00	28L	M36x2	33,90	36,00	7,50	28,20
30,00	30S	M42x2	39,90	42,00	13,50	30,20
35,00	35L	M45x2	42,90	45,00	10,50	35,30
38,00	38S	M52x2	49,90	52,00	16,00	38,30
42,00	42L	M52x2	49,90	52,00	11,00	42,30

British Standard Pipe (BSP)

Also referred to as Whitworth threads, the BSP thread type fittings seal using metal to metal angled surfaces or a combination of metal to metal and an O-ring.

The angle of the sealing surfaces is 60° for both forms.

There are two popular thread forms, British Standard Pipe Parallel (BSPP) and British Standard Pipe Tapered (BSPT).

Identification is made by measuring the outside diameter of the thread and the number of threads per inch (25.4 mm)

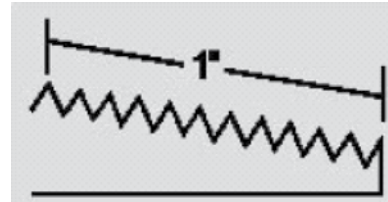

BSPP

metal to metal without O-ring

Standard
BS5200

Parker end configurations
92, B1, B2, B4, D9

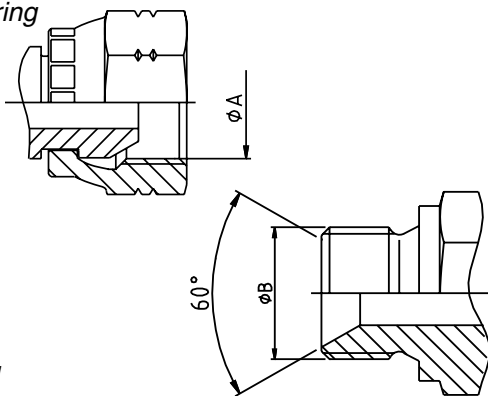

Tube OD	Size	BSP thread	ØA (mm)	ØB (mm)
6/10	-2	1/8-28	8,60	9,70
8/13	-4	1/4-19	11,50	13,20
12/17	-6	3/8-19	14,90	16,70
15/21	-8	1/2-14	18,60	20,90
18/23	-10	5/8-14	20,60	22,90
20/27	-12	3/4-14	24,10	26,40
26/34	-16	1"-11	30,30	33,20
33/42	-20	1.1/4-11	38,90	41,90
40/49	-24	1.1/2-11	44,90	47,80
50/60	-32	2-11	56,70	59,60

BSPP

metal to metal with O-ring

Standard
ISO 12151-6²⁾

Parker end configurations
EA, EB, EC, EE, D9

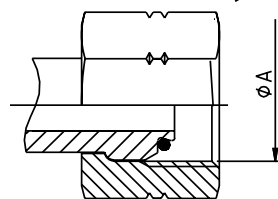

BSPT

fittings seal through the thread interface mechanism. Care should be taken not to confuse the BSPT fitting with the NPTF male fitting. BSPT has a 55° thread angle. NPTF has 60° thread angle.

Parker end configuration
91

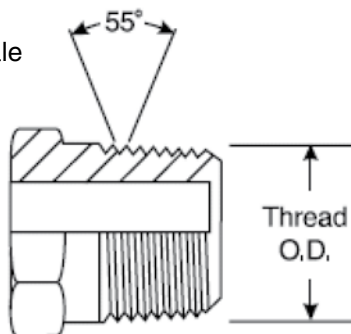

Tube	size	BSP thread	ØA (mm)
5/10	-2	1/8-28	9,73
8/13	-4	1/4-19	13,16
12/17	-6	3/8-19	16,66
15/21	-8	1/2-14	20,96
20/27	-12	3/4-14	26,44
26/34	-16	1"-11	33,25
33/42	-20	1.1/4-11	41,91
40/49	-24	1.1/2-11	47,80
50/60	-32	2-11	59,61

BSP Flat Seal

These fittings have BSP parallel threads but the sealing surface is flat. The seal is made when the composite seal is compressed against the female flat face.

Parker end configurations
B5, B6, B7

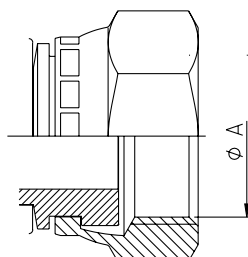

Tube OD	Size	BSP thread	ØA (mm)
6/10	-2	1/8-28	8,6
8/13	-4	1/4-19	11,5
12/17	-6	3/8-19	14,9
15/21	-8	1/2-14	18,6
18/23	-10	5/8-14	20,6
20/27	-12	3/4-14	24,1
26/34	-16	1"-11	30,3

²⁾ standard in preparation

French Metric 24° Cone Gas Fittings

Typical to the French market the French Gas fittings have a 24° sealing surfaces seat with metric straight threads. Although similar to German DIN fittings the threads differ in some sizes as the French Gas fittings have fine threads in all sizes whereas the German DIN fittings use standard threads in the larger sizes.

The sealing mechanism is metal to metal.

The fittings are not specified in any international standard.

Parker end configurations

F6, F9 (metric tube)

FG, F2, F4 (gas tube)

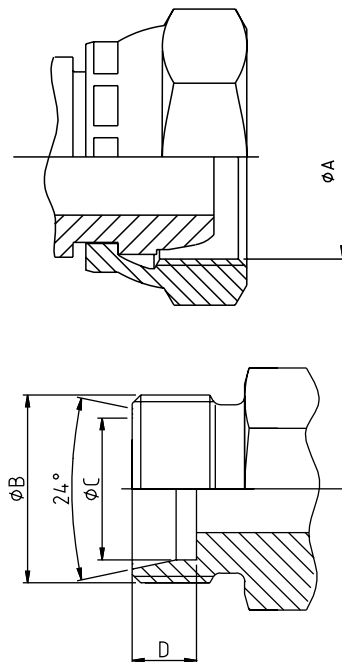

Tube OD	Specif.	Metric thread	ØA (mm)	ØB (mm)	ØC (mm)	D (mm)
6,00	6N	M12x1	11,00	12,00	6,20	9,00
8,00	8N	M14x1.5	12,50	14,00	8,15	9,00
10,00	10N	M16x1.5	14,50	16,00	10,20	9,00
12,00	12N	M18x1.5	16,50	18,00	12,15	9,00
13,25	13G	M20x1.5	18,50	20,00	13,50	9,00
14,00	14N	M20x1.5	18,50	20,00	14,15	9,00
15,00	15N	M22x1.5	20,50	22,00	15,15	9,00
16,00	16N	M24x1.5	22,50	24,00	16,15	9,00
16,75	17G	M24x1.5	22,50	24,00	17,00	9,00
18,00	18N	M27x1.5	25,50	27,00	18,15	9,00
20,00	20N	M27x1.5	25,50	27,00	20,15	9,00
21,25	21G	M30x1.5	28,50	30,00	21,50	9,00
22,00	22N	M30x1.5	28,50	30,00	22,15	9,00
25,00	25N	M33x1.5	31,50	33,00	25,15	9,00
26,75	27G	M36x1.5	34,50	36,00	27,00	9,00
28,00	28N	M36x1.5	34,50	36,00	28,25	9,00
30,00	30N	M39x1.5	37,50	39,00	30,25	9,00
32,00	32N	M42x1.5	40,50	42,00	32,25	9,00
33,25	34G	M45x1.5	43,50	45,00	33,80	9,00
35,00	35N	M45x1.5	43,50	45,00	35,25	9,00
38,00	38N	M48x1.5	46,50	48,00	38,25	9,00
40,00	40N	M52x1.5	50,50	52,00	40,35	9,00
42,25	42G	M52x1.5	50,50	52,00	42,55	9,00
48,25	49G	M58x2	55,90	58,00	49,00	11,00

Dryseal American Standard Taper Pipe Thread (NPTF)

This type of fitting uses the thread interface to seal and as such has a tapered thread that deforms and forms the seal.

They have 30° sealing angle surfaces, forming a 60° inverted (concave) seat. The fittings are most frequently seen on machines of US origin.

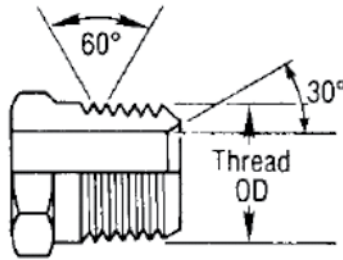

ØA dimension is measured on the 4th pitch of the thread

The NPTF male will mate with the NPTF, NPSF, or NPSM females.

Care should be taken not to confuse the NPTF fitting with the BSPT male fitting. NPTF fittings have a 60° thread angle. BSPT has a 55° thread angle.

Standard
SAE J516

Parker end configuration
01

size	NPTF thread	ØA (mm)	ØB (mm)
-2	1/8-27	10,24	8,73
-4	1/4-18	13,61	11,90
-6	3/8-18	17,05	15,90
-8	1/2-14	21,22	19,05
-12	3/4-14	26,56	24,60
-16	1-11,5	33,22	30,95
-20	1.1/4-11,5	41,98	39,69
-24	1.1/2-11,5	48,05	45,24
-32	2-11,5	60,09	57,15

SAE JIC 37°

Commonly referred to as just JIC fittings these metal to metal sealing type fittings have a 37° flare (sealing surface angle) and straight United National Fine straight Threads (UNF).

The original design specification for the fittings comes from the Society of Automotive Engineers (SAE) and these fittings are the most common American fitting type in Europe.

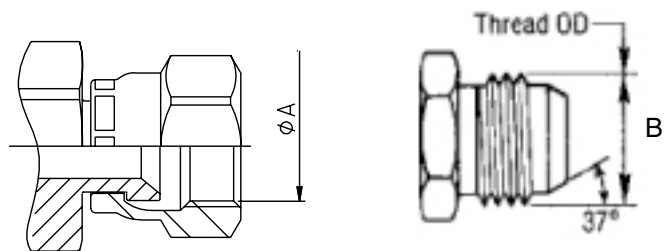

Standard
ISO 12151-5²⁾, ISO8434-2 and SAE J516

Parker JIC hose fittings are fully compatible with Parker Triple-lock Tube Fittings and adapters.

Parker end configurations
03, 06/68, 37/3V, 39/3W, 41/3Y, L9

Tube OD	Tube D (mm)	UNF thread	Size	ØA (mm)	ØB (mm)
3/16"		3/8-24	-3	8,60	9,50
1/4"	6	7/16-20	-4	10,00	11,10
5/16"	8	1/2-20	-5	11,60	12,70
3/8"	10	9/16-18	-6	13,00	14,30
1/2"	12	3/4-16	-8	17,60	19,10
5/8"	14-15-16	7/8-14	-10	20,50	22,20
3/4"	18-20	1.1/16-12	-12	24,60	27,00
7/8"	22	1.3/16-12	-14	28,30	30,10
1"	25	1.5/16-12	-16	31,30	33,30
1.1/4"	30-32	1.5/8-12	-20	39,20	41,30
1.1/2"	38	1.7/8-12	-24	45,60	47,60
2"		2.1/2-12	-32	61,50	63,50

²⁾ standard in preparation

SAE 45° Flare

The angle of the flare is commonly used as a name when referring to these metal to metal sealing fittings.

The female fittings have a 90° concave inverted seat, created by the 45° angle sealing surfaces.

The SAE 45° flare male will mate with an SAE 45° flare female only or a dual seat JIC 37°/SAE45°.

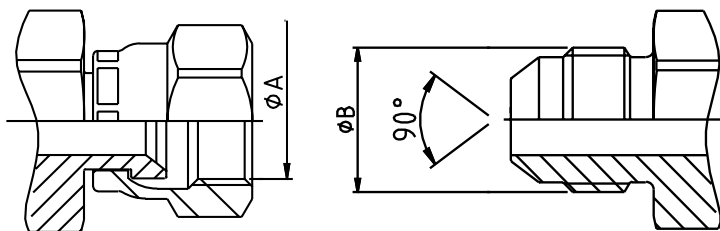

Standard
SAE J516

Parker end configurations
04, 08/68, 77/3V, 79/3W, 81/3Y

Tube OD	Size	UNF thread	ØA (mm)	ØB (mm)
1/4"	-4	7/16-20	9,90	11,10
5/16"	-5	1/2-20	11,50	12,70
3/8"	-6	5/8-18	14,30	15,90
1/2"	-8	3/4-16	17,50	19,10
5/8"	-10	7/8-14	20,60	22,20
3/4"	-12	1.1/16-14	25,00	27,00

SAE O-ring (Boss Type)

This male fitting has straight threads, a sealing face and an O-ring. It is compatible only with female boss type fittings generally found in the ports of the machines. Sealing is achieved through the O-ring of the male and through the sealing face of the female.

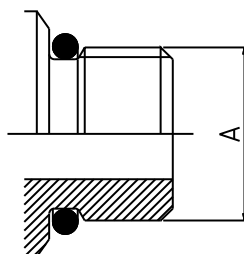

Parker end configuration
05

UNF thread	size	ØA (mm)
5/16-24	-2	7,93
3/8-24	-3	9,52
7/16-20	-4	11,11
1/2-20	-5	12,70
9/16-18	-6	14,28
3/4-16	-8	19,10
7/8-14	-10	22,22
1.1/16-12	-12	27,00
1.3/16-12	-14	30,10
1.5/16-12	-16	33,30
1.5/8-12	-20	41,30
1.7/8-12	-24	47,60
2.1/2-12	-32	63,50

O-ring Face Seal (ORFS)

ORFS fittings are becoming the most popular international fitting type used on global OEM machines due to their high level of sealing and their good vibration resistance. The fittings use the O-ring compression mechanism to seal. The female fittings have flat faces and straight threaded UNF swivel nuts. The male fittings have the O-ring in a groove in the flat face.

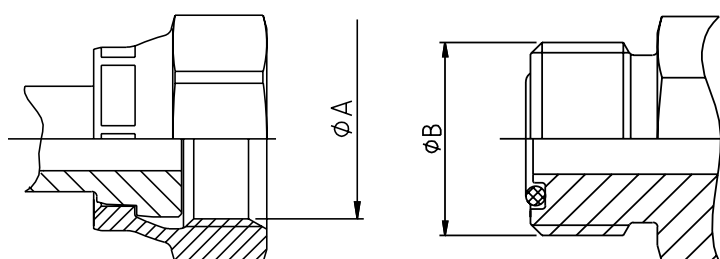

Seen as a major advantage, these fittings offer the possibility to build the hose assemblies into fixed distances/spaces, without having to move back other system components due the flat faces of the male and female fittings – the hose assembly can be slotted in.

Standard
ISO 12151-1, ISO8434-3 and SAE J516

Parker end configurations
JC, JM/J0, JS, JU, J1, J3, J5, J7, J9

Tube OD	Tube D (mm)	UNF thread	Size	ØA (mm)	ØB (mm)
1/4"	6	9/16-18	-4	13,00	14,20
3/8"	10	11/16-16	-6	15,90	17,50
1/2"	12	13/16-16	-8	19,10	20,60
5/8"	16	1-14	-10	23,80	25,40
3/4"	20	1.3/16-12	-12	28,20	30,10
1"	25	1.7/16-12	-16	34,15	36,50
1.1/4"	32	1.11/16-12	-20	40,50	42,90
1.1/2"	38	2-12	-24	48,80	50,80

Flange Fittings
Code 61 and Code 62

The 4-bolt split flange (or full flange) fitting is used worldwide for connecting high pressure hoses typically to pumps, motors and cylinders, where the hose assemblies are subjected to large pressure loadings. The sealing mechanism is through compression of the O-ring in the face of the flange head against the surface of the port/ connection.

The flange fittings are generally separated into two pressure classes referred to as 3000 psi (SFL) or 6000 psi (SFS). ISO 12151-3 refers to the flange fittings as code 61 for the 3000 psi and code 62 for the 6000 psi.

In addition to these flanges, customer specific Komatsu® and CATERPILLAR® flanges can also be found in the market.

Parker end configurations

Code 61 (3000 psi)

15, 16, 17, 19, P5, P7, P9

5000 psi (Code 61 dimensions)

4A, 4F, 4N

Code 62 (6000 psi)

6A, 6F, 6N, PA, PF, PN, 89

Caterpillar flange

XA, XF, XG, XN

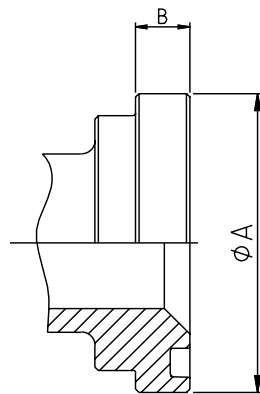

- Standard Code 61 for 3000 to 5000 psi max., depending on size
- High Pressure Code 62 for 6000 psi max. regardless of size

Flange (inch)	size	code 61	Code 62
1/2	-8	34,5 / 5000	41,3/ 6000
3/4	-12	34,5/ 5000	41,3/ 6000
1	-16	34,5/ 5000	41,3/ 6000
1.1/4	-20	27,5/ 4000	41,3/ 6000
1.1/2	-24	20,7/ 3000	41,3/ 6000
2	-32	20,7/3000	41,3/ 6000

Code 61 - SAE 3000PSI

Flange (inch)	Size	ØA (mm)	B (mm)	O-Ring
1/2"	-8	30,18	6,73	18,64x3,53
3/4"	-12	38,10	6,73	24,99x3,53
1"	-16	44,45	8,00	32,92x3,53
1.1/4"	-20	50,80	8,00	37,69x3,53
1.1/2"	-24	60,33	8,00	47,22x3,53
2"	-32	71,42	9,53	56,74x3,53
2.1/2"	-40	84,12	9,53	69,44x3,53
3"	-48	101,60	9,53	85,32x3,53

Code 62 - SAE 6000 PSI

Flange (inch)	Size	ØA (mm)	B (mm)	O-Ring
1/2"	-8	31,75	7,75	18,64x3,53
3/4"	-12	41,28	8,76	24,99x3,53
1"	-16	47,63	9,53	32,92x3,53
1.1/4"	-20	53,98	10,29	37,69x3,53
1.1/2"	-24	63,50	12,57	47,22x3,53
2"	-32	79,38	12,57	56,74x3,53

CATERPILLAR®

Flange (inch)	Size	ØA (mm)	B (mm)	D-Ring
3/4"	-12	41,28	14,22	25,40x5,00
1"	-16	47,63	14,22	31,90x5,00
1.1/4"	-20	53,98	14,22	38,20x5,00
1.1/2"	-24	63,50	14,22	44,70x5,00

Although not in the SAE or the ISO norm the size -10 (5/8) flange head is gaining popularity. This flange is often found on Komatsu equipment or hydrostatic drives in agricultural machines.

Flange (inch)	Size	ØA (mm)	B (mm)	O-Ring
5/8"	-10	34,25	6,00	21,7x3,5

4-Bolt Split Flange

A 4-bolt split flange is used to attach the flange fittings to their ports.

- Standard Code 61
for 3000 to 5000 psi max., depending on size
- High Pressure Code 62
for 6000 psi max. regardless of size

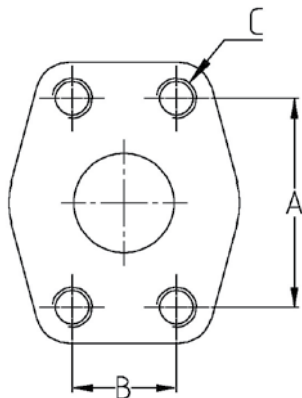

port dimensions

CODE 61 - SAE 3000 psi

Flange	Size	A		C	
		(mm)	(mm)	(inch)	(metr.)
1/2"	-8	38.1	17.5	5/16-18	M8x1,25
3/4"	-12	47.6	22.3	3/8-16	M10x1,5
1"	-16	52.4	26.2	3/8-16	M10x1,5
1-1/4"	-20	58.7	30.2	7/16-14	M10x1,5
1-1/2"	-24	69.9	35.7	1/2-13	M12x1,75
2"	-32	77.8	42.8	1/2-13	M12x1,75*

CODE 62 - SAE 6000 psi

Flange	Size	A		C	
		(mm)	(mm)	(inch)	(metr.)
1/2"	-8	40.5	18.2	5/16-18	M8x1,25
3/4"	-12	50.8	23.8	3/8-16	M10x1,5
1"	-16	57.2	27.8	7/16-14	M12x1,75
1-1/4"	-20	66.7	31.8	1/2-13	M12x1,75*
1-1/2"	-24	79.4	36.5	5/8-11	M16x2
2"	-32	96.8	44.4	3/4-10	M20x2,5

*M14x2 still used in the market but no longer in accordance with ISO6162

Japanese fittings - JIS

Japanese Industrial Standard (JIS) are seen on most Japanese equipment and use a 30° sealing angle seat and either British Standard Pipe Parallel or metric threads. Care must be taken not to confuse the JIS fittings with BSP or JIC fittings. The sealing mechanism of the fittings is the 30° metal to metal angled surfaces

Parker end configurations

MU, XU (Metric)

FU (BSP)

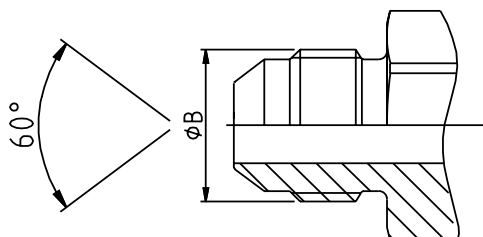
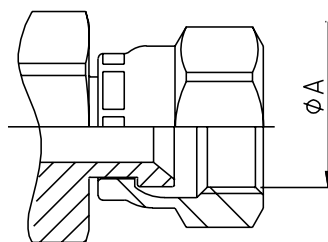

JIS 30° metric

	Symbol	Metric thread	ØA (mm)	ØB (mm)
	MU-6	M14x1.5	12,50	14,00
	MU-9	M18x1.5	16,50	18,00
	MU-12	M22x1.5	20,50	22,00
	MU-15	M27x2	25,00	27,00
	MU-19	M27x2	25,00	27,00
	MU-25	M33x2	31,00	33,00
	MU-32	M42x2	40,00	42,00
	MU-38	M50x2	48,00	50,00
	MU-50	M60x2	58,00	60,00

JIS 30° BSP

	Symbol	BSP thread	ØA (mm)	ØB (mm)
	GUI-3	1/8-28	8,60	9,70
	GUI-5/6	1/4-19	11,50	13,20
	GUI-8/9	3/8-19	14,90	16,70
	GUI-12	1/2-14	18,60	20,90
	GUI-15/19	3/4-14	24,10	26,40
	GUI-25	1"-11	30,30	33,20
	GUI-32	1.1/4-11	38,90	41,90
	GUI-38	1.1/2-11	44,90	47,80
	GUI-50	2-11	56,70	59,60

Parker's Motion & Control Technologies

At Parker, we're guided by a relentless drive to help our customers become more productive and achieve higher levels of profitability by engineering the best systems for their requirements. It means looking at customer applications from many angles to find new ways to create value. Whatever the motion and control technology need, Parker has the experience, breadth of product and global reach to consistently deliver. No company knows more about motion and control technology than Parker. For further info call 00800 27 27 5374



AEROSPACE

Key Markets

- Aircraft engines
- Business & general aviation
- Commercial transports
- Land-based weapons systems
- Military aircraft
- Missiles & launch vehicles
- Regional transports
- Unmanned aerial vehicles

Key Products

- Flight control systems & components
- Fluid conveyance systems
- Fluid metering delivery & atomization devices
- Fuel systems & components
- Hydraulic systems & components
- Inert nitrogen generating systems
- Pneumatic systems & components
- Wheels & brakes



CLIMATE CONTROL

Key Markets

- Agriculture
- Air conditioning
- Food, beverage & dairy
- Life sciences & medical
- Precision cooling
- Processing
- Transportation

Key Products

- CO² controls
- Electronic controllers
- Filter driers
- Hand shut-off valves
- Hose & fittings
- Pressure regulating valves
- Refrigerant distributors
- Safety relief valves
- Solenoid valves
- Thermostatic expansion valves



HYDRAULICS

Key Markets

- Aerospace
- Aerial lift
- Agriculture
- Construction machinery
- Forestry
- Industrial machinery
- Mining
- Oil & gas
- Power generation & energy
- Truck hydraulics

Key Products

- Diagnostic equipment
- Hydraulic cylinders & accumulators
- Hydraulic motors & pumps
- Hydraulic systems
- Hydraulic valves & controls
- Power take-offs
- Rubber & thermoplastic hose & couplings
- Tube fittings & adapters
- Quick disconnects

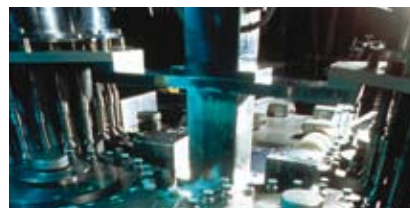

PNEUMATICS

Key Markets

- Aerospace
- Conveyor & material handling
- Factory automation
- Life science & medical
- Machine tools
- Packaging machinery
- Transportation & automotive

Key Products

- Air preparation
- Brass fittings & valves
- Manifolds
- Pneumatic accessories
- Pneumatic actuators & grippers
- Pneumatic valves & controls
- Quick disconnects
- Rotary actuators
- Rubber & thermoplastic hose & couplings
- Structural extrusions
- Thermoplastic tubing & fittings
- Vacuum generators, cups & sensors





ELECTROMECHANICAL

Key Markets

- Aerospace
- Factory automation
- Life science & medical
- Machine tools
- Packaging machinery
- Paper machinery
- Plastics machinery & converting
- Primary metals
- Semiconductor & electronics
- Textile
- Wire & cable

Key Products

- AC/DC drives & systems
- Electric actuators, gantry robots & slides
- Electrohydrostatic actuation systems
- Electromechanical actuation systems
- Human machine interface
- Linear motors
- Stepper motors, servo motors, drives & controls
- Structural extrusions



SEALING & SHIELDING

Key Markets

- Aerospace
- Chemical processing
- Consumer
- Energy, oil & gas
- Fluid power
- General industrial
- Information technology
- Life sciences
- Military
- Semiconductor
- Telecommunications
- Transportation

Key Products

- Dynamic seals
- Elastomeric o-rings
- EMI shielding
- Extruded & precision-cut, fabricated elastomeric seals
- Homogeneous & inserted elastomeric shapes
- High temperature metal seals
- Metal & plastic retained composite seals
- Thermal management



FILTRATION

Key Markets

- Food & beverage
- Industrial machinery
- Life sciences
- Marine
- Mobile equipment
- Oil & gas
- Power generation
- Process
- Transportation

Key Products

- Analytical gas generators
- Compressed air & gas filters
- Condition monitoring
- Engine air, fuel & oil filtration & systems
- Hydraulic, lubrication & coolant filters
- Process, chemical, water & microfiltration filters
- Nitrogen, hydrogen & zero air generators



PROCESS CONTROL

Key Markets

- Chemical & refining
- Food, beverage & dairy
- Medical & dental
- Microelectronics
- Oil & gas
- Power generation

Key Products

- Analytical sample conditioning products & systems
- Fluoropolymer chemical delivery fittings, valves & pumps
- High purity gas delivery fittings, valves & regulators
- Instrumentation fittings, valves & regulators
- Medium pressure fittings & valves
- Process control manifolds



FLUID & GAS HANDLING

Key Markets

- Aerospace
- Agriculture
- Bulk chemical handling
- Construction machinery
- Food & beverage
- Fuel & gas delivery
- Industrial machinery
- Mobile
- Oil & gas
- Transportation
- Welding

Key Products

- Brass fittings & valves
- Diagnostic equipment
- Fluid conveyance systems
- Industrial hose
- PTFE & PFA hose, tubing & plastic fittings
- Rubber & thermoplastic hose & couplings
- Tube fittings & adapters
- Quick disconnects

ENGINEERING YOUR SUCCESS.

Parker Worldwide

AE – UAE, Dubai
Tel: +971 4 8127100
parker.me@parker.com

AR – Argentina, Buenos Aires
Tel: +54 3327 44 4129

AT – Austria, Wiener Neustadt
Tel: +43 (0)2622 23501-0
parker.austria@parker.com

AT – Eastern Europe, Wiener Neustadt
Tel: +43 (0)2622 23501 970
parker.easteurope@parker.com

AU – Australia, Castle Hill
Tel: +61 (0)2-9634 7777

AZ – Azerbaijan, Baku
Tel: +994 50 2233 458
parker.azerbaijan@parker.com

BE/LU – Belgium, Nivelles
Tel: +32 (0)67 280 900
parker.belgium@parker.com

BR – Brazil, Cachoeirinha RS
Tel: +55 51 3470 9144

BY – Belarus, Minsk
Tel: +375 17 209 9399
parker.belarus@parker.com

CA – Canada, Milton, Ontario
Tel: +1 905 693 3000

CH – Switzerland, Etoy
Tel: +41 (0) 21 821 02 30
parker.switzerland@parker.com

CN – China, Shanghai
Tel: +86 21 5031 2525

CZ – Czech Republic, Klecany
Tel: +420 284 083 111
parker.czechrepublic@parker.com

DE – Germany, Kaarst
Tel: +49 (0)2131 4016 0
parker.germany@parker.com

DK – Denmark, Ballerup
Tel: +45 43 56 04 00
parker.denmark@parker.com

ES – Spain, Madrid
Tel: +34 902 33 00 01
parker.spain@parker.com

FI – Finland, Vantaa
Tel: +358 (0)20 753 2500
parker.finland@parker.com

FR – France, Contamine s/Arve
Tel: +33 (0)4 50 25 80 25
parker.france@parker.com

GR – Greece, Athens
Tel: +30 210 933 6450
parker.greece@parker.com

HK – Hong Kong
Tel: +852 2428 8008

HU – Hungary, Budapest
Tel: +36 1 220 4155
parker.hungary@parker.com

IE – Ireland, Dublin
Tel: +353 (0)1 466 6370
parker.ireland@parker.com

IN – India, Mumbai
Tel: +91 22 6513 7081-85

IT – Italy, Corsico (MI)
Tel: +39 02 45 19 21
parker.italy@parker.com

JP – Japan, Tokyo
Tel: +(81) 3 6408 3901

KR – South Korea, Seoul
Tel: +82 2 559 0400

KZ – Kazakhstan, Almaty
Tel: +7 7272 505 800
parker.easteurope@parker.com

LV – Latvia, Riga
Tel: +371 6 745 2601
parker.latvia@parker.com

MX – Mexico, Apodaca
Tel: +52 81 8156 6000

MY – Malaysia, Subang Jaya
Tel: +60 3 5638 1476

NL – The Netherlands, Oldenzaal
Tel: +31 (0)541 585 000
parker.nl@parker.com

NO – Norway, Ski
Tel: +47 64 91 10 00
parker.norway@parker.com

NZ – New Zealand, Mt Wellington
Tel: +64 9 574 1744

PL – Poland, Warsaw
Tel: +48 (0)22 573 24 00
parker.poland@parker.com

PT – Portugal, Leca da Palmeira
Tel: +351 22 999 7360
parker.portugal@parker.com

RO – Romania, Bucharest
Tel: +40 21 252 1382
parker.romania@parker.com

RU – Russia, Moscow
Tel: +7 495 645-2156
parker.russia@parker.com

SE – Sweden, Spånga
Tel: +46 (0)8 59 79 50 00
parker.sweden@parker.com

SG – Singapore
Tel: +65 6887 6300

SK – Slovakia, Banská Bystrica
Tel: +421 484 162 252
parker.slovakia@parker.com

SL – Slovenia, Novo Mesto
Tel: +386 7 337 6650
parker.slovenia@parker.com

TH – Thailand, Bangkok
Tel: +662 717 8140

TR – Turkey, Istanbul
Tel: +90 216 4997081
parker.turkey@parker.com

TW – Taiwan, Taipei
Tel: +886 2 2298 8987

UA – Ukraine, Kiev
Tel: +380 44 494 2731
parker.ukraine@parker.com

UK – United Kingdom, Warwick
Tel: +44 (0)1926 317 878
parker.uk@parker.com

US – USA, Cleveland
Tel: +1 216 896 3000

VE – Venezuela, Caracas
Tel: +58 212 238 5422

ZA – South Africa, Kempton Park
Tel: +27 (0)11 961 0700
parker.southafrica@parker.com

European Product Information Centre
Free phone: 00 800 27 27 5374
(from AT, BE, CH, CZ, DE, EE, ES, FI, FR, IE, IT, PT, SE, SK, UK)

